

Solar Plug-RWB1

RS232 To Wi-Fi+BLE Collector

User Manual

V 1.43



Product Features

- ✧ Supports WiFi 802.11b/g/n wireless standards
- ✧ Adopting RISC architecture SOC chip, with a maximum frequency of 160MHz, 276KB RAM, 2MB Flash, based on FreeRTOS system
- ✧ Support BLE 5.0 for diagnostic or local Bluetooth debugging and data collection functions
- ✧ Supports RS232 to WiFi data transmission, with a maximum serial port speed of 460800bps
- ✧ Support Solar Of Things energy management platform, web page or APP to monitor energy data
- ✧ Power supply: 5-12VDC

TABLE OF CONTENTS

TABLE OF CONTENTS.....2

FIGURE3

TABLE.....3

1. PRODUCT OVERVIEW.....4

1.1. Overview4

1.2. Product Parameters.....4

1.3. Main Application Areas5

2. HARDWARE INTRODUCTION6

2.1. Product Appearance Diagram6

2.2. Solar Plug-RWB1 Interface Pin Definition6

2.3. Solar Plug-RWB1 Indicator Light And Button Functions7

2.4. Internal Antenna.....8

2.5. Solar Plug-RWB1 Mechanical Dimensions8

2.6. Product Number9

APPENDIX A: CONTACT INFORMATION10

FIGURE

Figure 1.	Product Appearance Diagram.....	6
Figure 2.	RJ45 Pin	7
Figure 3.	Front Indicator Light And Reset Button Of The Product.....	7
Figure 4.	PCB Antenna Area	8
Figure 5.	Solar Plug-RWB1 Mechanical Dimensions	9
Figure 6.	Solar Plug-RWB1 Product Number Definition.....	9

TABLE

Table1.	Solar Plug-RWB1 Product Technical Parameters	4
Table2.	Interface Sub Models And Pin Definition Diagram.....	7
Table3.	Solar Plug-RWB1 Pin Description	7
Table4.	Solar Plug-RWB1 Indicator Light And Key Definition.....	7

History

- V 1.0** 2023-08-14 First Edition
- V 1.1** 2023-09-26 Update -01, -02 type GND pin difination.
- V 1.2** 2023-10-17 Update product appearance.
- V 1.3** 2023-11-14 Add -50 sub type.
- V 1.4** 2024-05-07 Add -51 sub type.
- V 1.41** 2024-06-07 Add -52、53 sub type.
- V 1.42** 2024-06-10 Add -05 sub type.
- V 1.43** 2024-09-10 Add -06 sub type.

1. PRODUCT OVERVIEW

1.1. Overview

The Solar Plug-RWB1 acquisition rod adopts a Wi-Fi+BLE data transmission method, which facilitates the collection and monitoring of data from inverters, energy storage devices, and other devices.

The Solar Plug-RWB1 is equipped with rich network protocols and an integrated RS232 data transmission interface, without the need for any driver, making it convenient for traditional serial devices to connect and use. It is compatible with four-color photovoltaic energy management and is suitable for the photovoltaic energy industry. You can log in to the photovoltaic platform to view the platform's functions in detail.

1.2. Product Parameters

Table1. Solar Plug-RWB1 Product Technical Parameters

Classification	Parameters
System Information	
Processor/Main Frequency	RISC 160MHz
Flash	2MB
RAM	276KB
Operating System	FreeRTOS
Wi-Fi Interface	
Wireless Standards	802.11 b/g/n
Frequency Range	2.412GHz ~ 2.472GHz
Network Mode	STA/AP/STA+AP
Security Type	WEP/WPA-PSK/WPA2-PSK/WPA3-SAE
Encryption	WEP64/WEP128/TKIP/AES
Transmitting Power	802.11b: +17dBm ± 1.5dBm (@11Mbps) 802.11g: +15dBm ± 1.5dBm (@54Mbps) 802.11n: +14dBm ± 1.5dBm (@HT20, MCS7)
Receiving Sensitivity	802.11b: -96dBm (@1Mbps) 802.11b: -89dBm (@11Mbps) 802.11g: -91dBm (@6Mbps) 802.11g: -76dBm (@54Mbps) 802.11n: -91dBm (@MCS0) 802.11n: -73dBm (@MCS7)
Antenna Option	PCB Internal Antenna
BLE Interface	
Wireless Standards	BLE5.0
Frequency Range	2.402GHz ~ 2.480GHz

Transmitting Power	Max 15dBm
Receiving Sensitivity	-97dBm
Serial Port	
Number of Port	1
Interface Standard	RS232
Data Bit	7, 8
Stop Bit	1, 2
Check Bit	None, Even, Odd
Baud Rate	TTL: 1200 bps~460800 bps
Flow Control	No flow control
Software	
Collocation Method	APP
Firmware update	Serial port or OTA network upgrade
基本参数	
Size	66mm x 19.8mm x 10.8mm
Working Temperature	-40 ~ 85°
Storage Environment	-45 ~ 105°C, 5 ~ 95% RH (无凝水)
Input Voltage	5~12VDC
Average Current	<30mA@9V
Average Power Consumption	180mW

1.3. Main Application Areas

The Solar Plug-RWB1 connects serial devices to the Internet and transmits serial data in accordance with the TCP/IP protocol.

- Monitoring of photovoltaic solar energy and energy storage;

2. HARDWARE INTRODUCTION

Solar Plug-RWB1 is a WiFi+BLE solution for serial device networking, which enables data transmission through routers, making product integration very easy.

2.1. Product Appearance Diagram

The product appearance diagram is as follows.



Figure 1. Product Appearance Diagram

2.2. Solar Plug-RWB1 Interface Pin Definition

The RJ45 pin labels are shown in the following figure. The product sub models support different wire sequence types, and corresponding wire sequence models need to be selected according to actual needs.

The Solar Plug RWB1 defaults to using RS232 level format. If the actual product requires the use of RS485 or TTL electrical interfaces, please contact our company for further details.

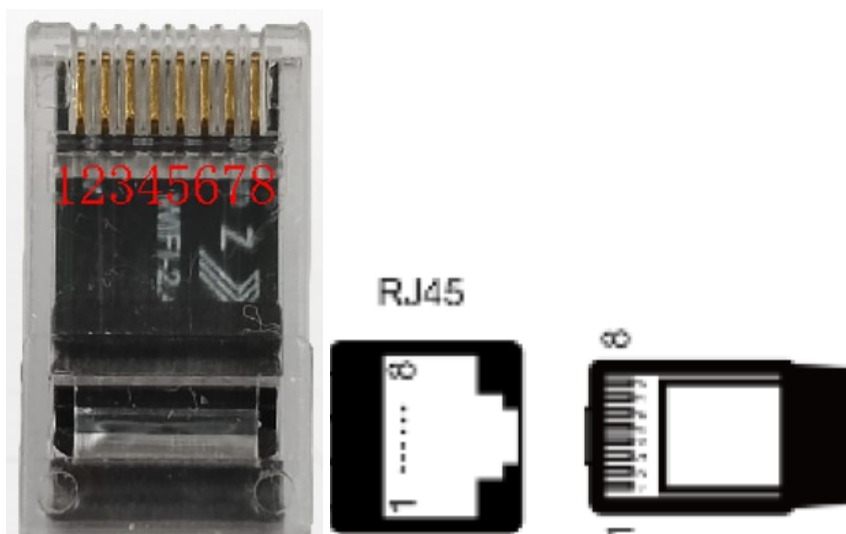

Figure 2. RJ45 Pin

Table2. Interface Sub Models And Pin Definition Diagram

Sub Model Code	Interface Form	PIN1	PIN2	PIN3	PIN4	PIN5	PIN6	PIN7	PIN8
-01	RS232	RXD	TXD	VCC	NC	NC	NC	NC	GND
-02	RS232	TXD	RXD	VCC	NC	NC	NC	NC	GND
-03	RS232	TXD	RXD	NC	VCC	NC	NC	NC	GND
-04	RS232	RXD	TXD	NC	VCC	NC	NC	NC	GND
-05	RS232	RXD	GND	TXD	VCC	NC	NC	NC	NC
-06	RS232	NC	VCC	RXD	NC	GND	TXD	NC	NC
-50	RS485	GND	GND	RS485 B-	VCC	VCC	RS485 A+	NC	NC
-51	RS485	RS485 A+	RS485 B-	NC	VCC	NC	NC	NC	GND
-52	RS485	VCC	GND	NC	NC	NC	NC	RS485 A+	RS485 B-
-53	RS485	RS485 B-	RS485 A+	NC	VCC	NC	NC	NC	GND

Table3. Solar Plug-RWB1 Pin Description

Signal Description	Signal Type	Description
VCC	P	5~12VDC power supply input
GND	P	GND Ground
TXD	O	RS232 level serial port output
RXD-	I	RS232 level serial port input

<Description>:

I — Input; O — Output; Power—Power supply

NC — No Connection

2.3. Solar Plug-RWB1 Indicator Light And Button Functions

There are 4 LED indicator lights and a Reload reset button on the front of the product.



Figure 3. Front Indicator Light And Reset Button Of The Product

Table4. Solar Plug-RWB1 Indicator Light And Key Definition

Pin	Description	Network Name	Signal Type	Note
-----	-------------	--------------	-------------	------

Pin	Description	Network Name	Signal Type	Note
PWR	Power indicator light	PWR	O	On: Power supply is normal Off: Abnormal power supply
COM	Serial port transmission indicator light	COM	O	Off: No data interaction Off for 0.3 seconds, on for 0.9 seconds: serial port outputs data Off for 0.3 seconds, on for 0.3 seconds: serial port receives data On: Bidirectional sending and receiving.
NET	Network status indicator light	NET	O	Off for 0.3 seconds, on for 3 seconds: Connect to the router in STA mode Off for 0.3 seconds, on for 0.3 seconds: STA is not connected to the router
SRV	Server connection indicator light	SRV	O	On: Connected to server Off: Not connected to the server
Reload	Reset Button	Reload	I	The default height is high. Press and hold this key (>4S) and release it to restore the module to its factory settings.

2.4. Internal Antenna

When using a built-in antenna in the product (red area), the following precautions for built-in antennas must be observed:

- ✓ The antenna should be kept away from metal and should not be placed inside products wrapped in metal;



Figure 4. PCB Antenna Area

2.5. Solar Plug-RWB1 Mechanical Dimensions

The dimensions of different sub models of Solar Plug-RWB1 are defined as follows (in millimeters).

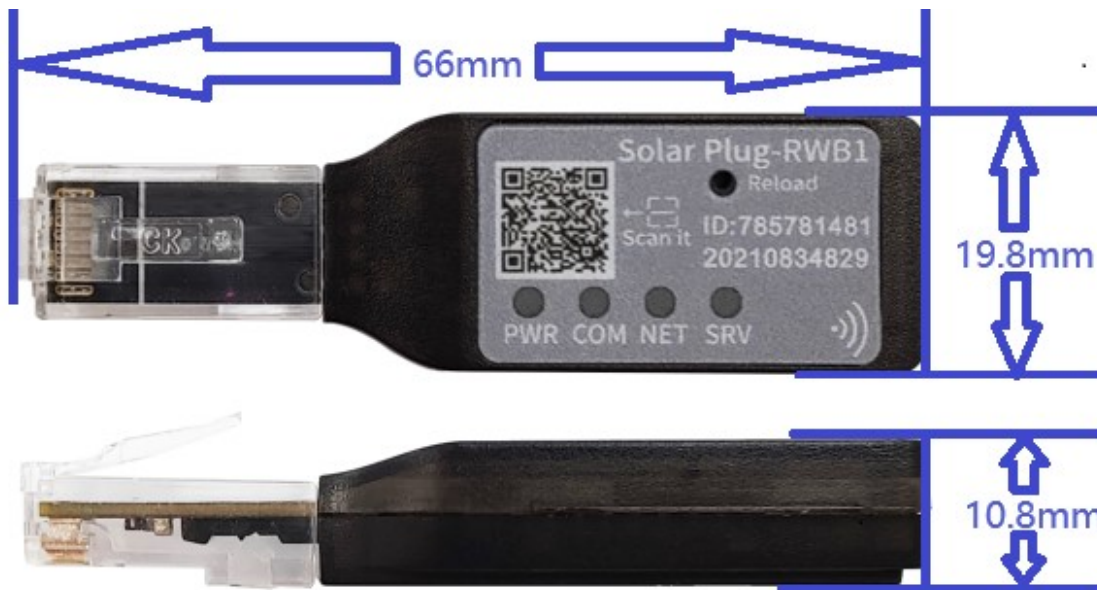

Figure 5. Solar Plug-RWB1 Mechanical Dimensions

2.6. Product Number

According to customer requirements, Solar Plug RWB1 provides different configuration versions, as follows:

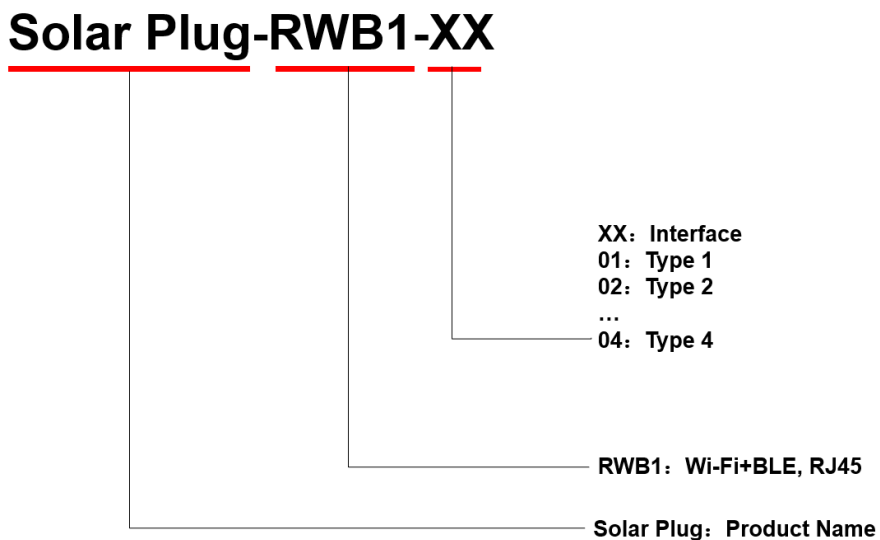

Figure 6. Solar Plug-RWB1 Product Number Definition

APPENDIX A: CONTACT INFORMATION

Website: www.hi-flying.com

Contact person:

Sales: sales@iotworkshop.com

Support: support@iotworkshop.com

Service: service@iotworkshop.com

Business: business@iotworkshop.com
