

R&TTE (Radio) TEST REPORT
for
High-Flying Electronics Technology Co., Ltd

Embedded Wi-Fi Module
Model No.: HF-LPT100

Prepared for : High-Flying Electronics Technology Co., Ltd
Address : Room 511, #7Building, No.365 Chuanhong Road, Pudong,
Shanghai, China

Prepared By : Shenzhen Anbotek Compliance Laboratory Limited
Address : 1/F., Building 1, SEC Industrial Park, No.0409 Qianhai Road,
Nanshan District, Shenzhen, Guangdong, China
Tel: (86) 755-26066544
Fax: (86) 755-26014772

Report Number : 201311815T
Date of Test : Nov. 18~ 29, 2013
Date of Report : Nov. 29, 2013

TABLE OF CONTENT

Description

Page

Test Report

1. GENERAL INFORMATION	4
1.1. Description of Device (EUT).....	4
1.2. Auxiliary Equipment Used during Test	5
1.3. Description of Test Facility	5
1.4. Measurement Uncertainty.....	5
1.5. Test Standards.....	5
2. TECHNICAL TEST	6
2.1. Summary of Test Results.....	6
2.2. Test Report	6
2.3. Description of Test Modes.....	6
3. TECHNICAL REQUIREMENTS	7
3.1 MAXIMUM TRANSMIT POWER	7
3.2 MAXIMUM SPECTRAL POWER DENSITY	11
3.3 FREQUENCY RANGE	14
3.4 MEDIUM ACCESS PROTOCOL	17
3.5 TRANSMITTER SPURIOUS EMISSIONS	18
3.6 RECEIVER SPURIOUS EMISSIONS	23
APPENDIX I (TEST PHOTOGRAPHS)	26
1. Photo of Emission Test.....	26

APPENDIX I (Test Photographs) (1 Page)

TEST REPORT

Applicant : High-Flying Electronics Technology Co., Ltd
Manufacturer : High-Flying Electronics Technology Co., Ltd
EUT : Embedded Wi-Fi Module
Model No. : HF-LPT100
Serial No. : N/A
Trade Mark : High-Flying
Rating : DC 3.1V-3.6V, 240mA

Measurement Procedure Used:

ETSI EN 300 328 V1.8.1 (2012-06)

The device described above is tested by Shenzhen Anbotek Compliance Laboratory Limited to determine the maximum emission levels emanating from the device and the severe levels of the device can endure and its performance criterion. The measurement results are contained in this test report and Shenzhen Anbotek Compliance Laboratory Limited is assumed full of responsibility for the accuracy and completeness of these measurements. Also, this report shows that the EUT (Equipment Under Test) is technically compliant with the EN 300 328 requirements.

This report applies to above tested sample only and shall not be reproduced in part without written approval of Shenzhen Anbotek Compliance Laboratory Limited.

Date of Test : Nov. 18~ 29, 2013

Prepared by :



Rock zeng
(Engineer / Rock Zeng)

Reviewer :

Sally zhang
(Project Manager/Sally Zhang)

Approved & Authorized Signer :

Tom Chen
(Manager/Tom Chen)

1. GENERAL INFORMATION

1.1. Description of Device (EUT)

EUT : Embedded Wi-Fi Module

Model Number : HF-LPT100

Test Power Supply : AC 230V, 50Hz for adapter

Frequency : 2412-2472MHz(802.11b/g/n)

Channels : 802.11b, 802.11g, 802.11n,(HT20) 13 Channels
802.11n(HT40) 9 Channels

Antenna Gain : 2 dBi

Current Consumption : N/A

Applicant : High-Flying Electronics Technology Co., Ltd
Address : Room 511, #7Building, No.365 Chuanhong Road, Pudong,
Shanghai, China

Manufacturer : High-Flying Electronics Technology Co., Ltd
Address : Room 511, #7Building, No.365 Chuanhong Road, Pudong,
Shanghai, China

Factory : Shanghai Quick Turn Electronic Co., Ltd.
Address : 4F, Bldg. 1, No. 1069 Chuansha Road, Pudong New District,
Shanghai, China

Date of receiver : Nov. 18, 2013

Date of Test : Nov. 18~ 29, 2013

1.2. Auxiliary Equipment Used during Test

N/A

1.3. Description of Test Facility

The test facility is recognized, certified, or accredited by the following organizations:

CNAS - LAB Code: L3503

Shenzhen Anbotek Compliance Laboratory Limited., Laboratory has been assessed and in compliance with CNAS/CL01: 2006 accreditation criteria for testing laboratories (identical to ISO/IEC 17025:2005 General Requirements) for the Competence of Testing Laboratories.

FCC-Registration No.: 752021

Shenzhen Anbotek Compliance Laboratory Limited, EMC Laboratory has been registered and fully described in a report filed with the (FCC) Federal Communications Commission. The acceptance letter from the FCC is maintained in our files. Registration 752021, July 10, 2013.

IC-Registration No.: 8058A-1

Shenzhen Anbotek Compliance Laboratory Limited., EMC Laboratory has been registered and fully described in a report filed with the (IC) Industry Canada. The acceptance letter from the IC is maintained in our files. Registration 8058A, February 22, 2013.

Test Location

All Emissions tests were performed at
Shenzhen Anbotek Compliance Laboratory Limited. at 1/F., Building 1, SEC Industrial Park, No.0409 Qianhai Road, Nanshan District, Shenzhen, Guangdong, China

1.4. Measurement Uncertainty

Radiation Uncertainty : Ur = 4.3dB

Conduction Uncertainty : Uc = 3.4dB

1.5. Test Standards

ETSI EN 300 328 V1.8.1 (2012-06)
Electromagnetic compatibility
and Radio spectrum Matters (ERM);
wideband transmission systems;
Data transmission equipment operating
in the 2,4GHz ISM band and
using wide band modulation techniques;
Harmonized EN covering essential requirements
under article 3.2 of the R&TTE Directive

2. Technical Test

2.1. Summary of Test Results

No Deviations from the technical specification(s) were ascertained in the course of the tests Performed	
Final Verdict: (only “Passed” if all single measurements are “Passed”)	Passed

2.2. Test Report

Test Report Reference

List of Measurements		
Description of Test	Rule	Result
Maximum transmit power	Section 4.3.1	Complies
Maximum e.i.r.p spectral density	Section 4.3.2	Complies
Frequency range	Section 4.3.3	Complies
Dwell time	Section 4.3.4.1	N/A
Hopping channel	Section 4.3.4.2	N/A
Hopping sequence	Section 4.3.4.3	N/A
Medium access protocol	Section 4.3.5	Complies
Transmitter spurious emissions	Section 4.3.6	Complies
Receiver spurious emissions	Section 4.3.7	Complies

Note: The clause numbers are referenced to ETSI EN 300 328.
N/A means Not Applicable.

2.3. Description of Test Modes

The EUT has been tested under operating condition.

Software used to control the EUT for staying in continuous transmitting and receiving mode is programmed.

IEEE802.11b: Channel 1(2412MHz), Channel 7(2442MHz) and Channel 13(2472MHz) with 1Mbps Worst data rate (worst case) are chosen for the final testing.

IEEE802.11g: Channel 1(2412MHz), Channel 7(2442MHz) and Channel 13(2472MHz) with 6Mbps data rate (the worst case) are chosen for the final testing.

IEEE802.11n(HT20): Channel 1(2412MHz), Channel 7(2442MHz) and Channel 13(2472MHz) with 54Mbps Worst data rate (worst case) are chosen for the final testing.

IEEE802.11n(HT40): Channe3(2422MHz), Channel 7(2442MHz) and Channel 11 (2462MHz) with 108Mbps data rate (the worst case) are chosen for the final testing.

3. Technical Requirements

3.1 Maximum Transmit Power

Applicable Standard

According to ETSI EN 300 328 V1.8.1 §4.3.1.2, the equivalent isotropic radiated power shall be equal to or less than -10dBW (100 mW) e.i.r.p. This limit shall apply for any combination of power level and intended antenna assembly.

Test Equipment

Radiated Emission Measurement (RF)

Item	Equipment	Manufacturer	Model No.	Serial No.	Last Cal.	Cal. Interval
1.	Spectrum Analysis	Agilent	E4407B	US39390582	Aug. 09, 2013	1 Year
2.	Preamplifier	Instruments corporation	EMC011830	980100	Aug. 09, 2013	1 Year
3.	EMI Test Receiver	Rohde & Schwarz	ESPI	101604	Apr. 23, 2013	1 Year
4.	Double Ridged Horn Antenna	Instruments corporation	GTH-0118	351600	Aug. 09, 2013	3 Year
5.	Bilog Broadband Antenna	Schwarzbeck	VULB9163	VULB 9163-289	Apr. 23, 2013	3 Year
6.	Pre-amplifier	SONOMA	310N	186860	Apr. 23, 2013	1 Year
7.	EMI Test Software EZ-EMC	SHURPLE	N/A	N/A	N/A	N/A

Radiation Uncertainty : Ur = 4.3dB

Test Procedure

The measurement shall be performed using normal operation of the equipment with modulation, using the test data sequence, applied. The test procedure shall be as follows:

Step 1:

using a suitable means, the output of the transmitter shall be coupled to a diode detector; the output of the diode detector shall be connected to the vertical channel of an oscilloscope; the combination of the diode detector and the oscilloscope shall be capable of faithfully reproducing the envelope peaks and the duty cycle of the transmitter output signal.

The observed duty cycle of the transmitter (Tx on/(Tx on + Tx off)) shall be noted as x, (0<x<1) and recorded in the test report. For the purpose of testing, the equipment shall be operated with a duty cycle that is equal to or more than 0.1.

Step 2

the average output power of the transmitter shall be determined using a wideband, calibrated RF power meter with a thermocouple detector or an equivalent thereof and, where applicable, with an integration period that exceeds the repetition period of the transmitter by a factor 5 or more. The observed value shall be recorded as "A" (in dBm); the e.i.r.p. shall be calculated from the above measured power output A, the observed duty cycle x,

and the applicable antenna assembly gain “G” in dBi, according to the formula:

$$P = A + G + 10 \log(1/x)$$

P shall not exceed the value specified for Effective radiated power.

Step 3

the measurement set up as given under step 1 shall be used to determine on the oscilloscope the peak of the envelope of the output signal of the transmitter.

The maximum deviation of the Y-trace of the oscilloscope shall be recorded as “B”;

Step 4

the transmitter shall be replaced by a signal generator. The output frequency of the signal shall be made equal to the center of the frequency range occupied by the transmitter;

the signal generator shall be unmodulated. The output power of the signal generator shall be raised to a level such that the deviation of the Y-trace of the oscilloscope reaches level B, as indicated in step 3;

this output power level “C” (in dBm) of the signal generator shall be determined using a wideband, calibrated RF power meter with a thermocouple detector or an equivalent thereof;

level C shall not exceed by more than 3 dB the value specified for effective radiated power minus the applicable antenna assembly gain G in dBi.

Test Data

Environmental Conditions

Temperature:	25 ° C
Relative Humidity:	56%
ATM Pressure:	100.9 kPa

Duty Cycle Measurement X: (Ton/Ton+Toff) =	1
Antenna Assembly Gain G:	2 dBi
Cable Loss C=	0.6 dB
$P = A + C + G + 10 \log(1/x)$	

Test Mode: IEEE 802.11 b

Test Conditions			Low Freq. (2412MHz)	Mid Freq. (2442MHz)	High Freq. (2472MHz)
Tmin(-10)°C	Vmin(207V)	Measured Power	16.19	16.06	16.19
		EIRP	18.79	18.66	18.79
	Vmax(253V)	Measured Power	16.27	16.04	16.22
		EIRP	18.87	18.64	18.82
Tnom(+25)°C	Vnom(230V)	Measured Power	16.26	15.99	16.23
		EIRP	18.86	18.59	18.83
Tmax(+55)°C	Vmin(207V)	Measured Power	16.25	16.08	16.17
		EIRP	18.85	18.68	18.77
	Vmax(253V)	Measured Power	16.31	15.97	16.18
		EIRP	18.91	18.57	18.78
Limit			Average Limit = 20 dBm		

Test Mode: IEEE 802.11g

Test Conditions			Low Freq. (2412MHz)	Mid Freq. (2442MHz)	High Freq. (2472MHz)
Tmin(-10)°C	Vmin(207V)	Measured Power	15.19	15.33	15.07
		EIRP	17.79	17.93	17.67
	Vmax(253V)	Measured Power	15.17	15.41	15.05
		EIRP	17.77	18.01	17.65
Tnom(+25)°C	Vnom(230V)	Measured Power	15.09	15.36	14.98
		EIRP	17.69	17.96	17.58
Tmax(+55)°C	Vmin(207V)	Measured Power	15.14	15.28	15.01
		EIRP	17.74	17.88	17.61
	Vmax(253V)	Measured Power	15.08	15.37	15.09
		EIRP	17.68	17.97	17.69
Limit			Average Limit = 20 dBm		

Test Mode: IEEE 802.11 n(HT20)

Test Conditions			Low Freq. (2412MHz)	Mid Freq. (2442MHz)	High Freq. (2472MHz)
Tmin(-10)°C	Vmin(207V)	Measured Power	14.73	14.59	14.71
		EIRP	17.33	17.19	17.31
	Vmax(253V)	Measured Power	14.78	14.54	14.78
		EIRP	17.38	17.14	17.38
Tnom(+25)°C	Vnom(230V)	Measured Power	14.63	14.65	14.74
		EIRP	17.23	17.25	17.34
Tmax(+55)°C	Vmin(207V)	Measured Power	14.67	14.61	14.63
		EIRP	17.27	17.21	17.23
	Vmax(253V)	Measured Power	14.71	14.69	14.72
		EIRP	17.31	17.29	17.32
Limit			Average Limit = 20 dBm		

Test Mode: IEEE 802.11n(HT40)

Test Conditions			Low Freq. (2422MHz)	Mid Freq. (2442MHz)	High Freq. (2462MHz)
Tmin(-10)°C	Vmin(207V)	Measured Power	13.81	13.98	13.87
		EIRP	16.41	16.58	16.47
	Vmax(253V)	Measured Power	13.79	14.02	13.82
		EIRP	16.39	16.62	16.42
Tnom(+25)°C	Vnom(230V)	Measured Power	13.84	13.89	13.91
		EIRP	16.44	16.49	16.51
Tmax(+55)°C	Vmin(207V)	Measured Power	13.83	13.94	13.94
		EIRP	16.43	16.54	16.54
	Vmax(253V)	Measured Power	13.82	13.92	13.86
		EIRP	16.42	16.52	16.46
Limit			Average Limit = 20 dBm		

3.2 Maximum Spectral Power Density

Applicable Standard

According to ETSI EN 300 328 V1.8.1 §4.3.2.2, for wide band modulations other than FHSS (e.g. DSSS, OFDM, etc.), the maximum spectrum power density is limited to 10 mW per MHz e.i.r.p.

Test Equipment

Radiated Emission Measurement (RF)

Item	Equipment	Manufacturer	Model No.	Serial No.	Last Cal.	Cal. Interval
1.	Spectrum Analysis	Agilent	E4407B	US39390582	Aug. 09, 2013	1 Year
2.	Preamplifier	Instruments corporation	EMC011830	980100	Aug. 09, 2013	1 Year
3.	EMI Test Receiver	Rohde & Schwarz	ESPI	101604	Apr. 23, 2013	1 Year
4.	Double Ridged Horn Antenna	Instruments corporation	GTH-0118	351600	Aug. 09, 2013	3 Year
5.	Bilog Broadband Antenna	Schwarzbeck	VULB9163	VULB 9163-289	Apr. 23, 2013	3 Year
6.	Pre-amplifier	SONOMA	310N	186860	Apr. 23, 2013	1 Year
7.	EMI Test Software EZ-EMC	SHURPLE	N/A	N/A	N/A	N/A

Radiation Uncertainty : Ur = 4.3dB

Test Procedure

Step 1

the measurement setup shall be calibrated with a CW signal from a calibrated source; the reference signal should have a strength of 10 dBm;
the settings of the spectrum analyzer shall be:
center frequency : equal to the signal source;
resolution BW: 100kHz for FHSS, 1 MHz for DSSS;
video BW: Same;
detector mode: positive peak;
averaging: off;
span: zero Hz;
amplitude: adjust for middle of the instrument's range.

Step 2

the calibrating signal power shall be reduced to 0 dBm and it shall be verified that the power meter reading also reduces by 10 dB.

Step 3

connect the equipment to be measured. Using the following settings of the spectrum analyzer in combination with “max hold” function, find the frequency of highest power output in the power envelope;

center Frequency: equal to operating frequency;

resolution BW: 100kHz for FHSS, 1 MHz for DSSS;

video BW: same;

detector mode: positive peak;

averaging: off;

Span: 3 times the spectrum width;

Amplitude: adjust for middle of the instrument’s range.

the frequency found shall be recorded in the test report.

Step 4

set the center frequency of the spectrum analyzer to the found frequency and switch to zero span. The power meter indicates the measured power density. The power density e.i.r.p. is calculated from the measured power density and the declared antenna assembly gain(s).

Anbotek

Test Data

Environmental Conditions

Temperature:	25 °C
Relative Humidity:	53 %
ATM Pressure:	100.9 kPa

Test Mode: Transmitting

Test Result: PASS

Test dates see the following pages

Test mode	Transmitting frequency	Measured (dBm/ MHz)	Limit (dBm/ MHz)	Test Result
802.11b	2412	6.98	10	Pass
	2442	7.07	10	Pass
	2472	6.03	10	Pass
802.11g	2412	-8.98	10	Pass
	2442	-6.35	10	Pass
	2472	-9.25	10	Pass
802.11n(HT20)	2412	-4.87	10	Pass
	2442	-6.46	10	Pass
	2472	-5.85	10	Pass
802.11n(HT40)	2422	-6.16	10	Pass
	2442	-7.85	10	Pass
	2462	-6.13	10	Pass

3.3 Frequency range

Applicable Standard

The frequency range of the equipment is determined by the lowest and highest frequencies occupied by the power envelope.

fH is the highest frequency of the power envelope: it is the frequency furthest above the frequency of maximum power where the output power drops below the level of -80 dBm/Hz e.i.r.p. spectral power density (-30 dBm if measured in a 100 kHz bandwidth).

fL is the lowest frequency of the power envelope; it is the frequency furthest below the frequency of maximum power where the output power drops below the level equivalent to -80 dBm/Hz e.i.r.p. spectral power density (or -30 dBm if measured in a 100 kHz bandwidth).

For a given operating frequency, the width of the power envelope is (fH - fL). In equipment that allows adjustment or selection of different operating frequencies, the power envelope takes up different positions in the allocated band. The frequency range is determined by the lowest value of fL and the highest value of fH resulting from the adjustment of the equipment to the lowest and highest operating frequencies.

Test Equipment

Radiated Emission Measurement (RF)

Item	Equipment	Manufacturer	Model No.	Serial No.	Last Cal.	Cal. Interval
1.	Spectrum Analysis	Agilent	E4407B	US39390582	Aug. 09, 2013	1 Year
2.	Preamplifier	Instruments corporation	EMC011830	980100	Aug. 09, 2013	1 Year
3.	EMI Test Receiver	Rohde & Schwarz	ESPI	101604	Apr. 23, 2013	1 Year
4.	Double Ridged Horn Antenna	Instruments corporation	GTH-0118	351600	Aug. 09, 2013	3 Year
5.	Bilog Broadband Antenna	Schwarzbeck	VULB9163	VULB 9163-289	Apr. 23, 2013	3 Year
6.	Pre-amplifier	SONOMA	310N	186860	Apr. 23, 2013	1 Year
7.	EMI Test Software EZ-EMC	SHURPLE	N/A	N/A	N/A	N/A

Radiation Uncertainty : Ur = 4.3dB

Test Procedure

- a) MI Test Receiver in video averaging mode with a minimum of 50 sweeps selected;
- b) Select the lowest operating frequency of the equipment under test and activate the transmitter with modulation applied. The RF emission of the equipment shall be displayed on the spectrum analyzer.

- c) Using the marker of the spectrum analyzer, find lowest frequency below the operating frequency at which spectral power density drops below the required value.
- d) Select the highest operating frequency of the equipment under test and find the highest frequency at which the spectral power density drop below the required value.
- e) The difference between the frequencies measured in step 3 and step 4 is the operating frequency range.

Test Data

Environmental Conditions

Temperature:	25 °C
Relative Humidity:	53 %
ATM Pressure:	100.9 kPa

Test Result: Pass
Test Mode: Transmitting

For 802.11b

Test Conditions		Frequency (MHz) at -30dBm/100KHz (eirp)	
Temperature	Voltage(V)	fL at Low Channel (>2400MHz)	fH at High Channel (<2483.5MHz)
Tmin = -10°C	207	2402.04	2481.88
	253	2402.09	2481.79
Tnor = 25°C	230	2401.93	2481.73
Tmax =55°C	207	2402.01	2481.78
	253	2402.96	2481.83

For 802.11g

Test Conditions		Frequency (MHz) at -30dBm/100KHz (eirp)	
Temperature	Voltage(V)	fL at Low Channel (>2400MHz)	fH at High Channel (<2483.5MHz)
Tmin = -10°C	207	2401.43	2482.12
	253	2401.45	2482.07
Tnor = 25°C	230	2401.51	2482.19
Tmax =55°C	207	2401.52	2482.12
	253	2401.47	2482.15

For 802.11n (HT20)

Test Conditions		Frequency (MHz) at -30dBm/100KHz (eirp)	
Temperature	Voltage(V)	fL at Low Channel (>2400MHz)	fH at High Channel (<2483.5MHz)
Tmin = -10°C	207	2401.29	2482.75
	253	2401.13	2482.71
Tnor = 25°C	230	2401.25	2482.66
Tmax =55°C	207	2401.28	2482.65
	253	2401.19	2482.64

For 802.11n (HT40)

Test Conditions		Frequency (MHz) at -30dBm/100KHz (eirp)	
Temperature	Voltage(V)	fL at Low Channel (>2400MHz)	fH at High Channel (<2483.5MHz)
Tmin = -10°C	207	2400.63	2482.80
	253	2400.64	2482.67
Tnor = 25°C	230	2400.45	2482.75
Tmax =55°C	207	2400.82	2482.52
	253	2400.72	2482.73

3.4 Medium Access Protocol

Definition and Requirement

A medium access protocol is a mechanism designed to facilitate spectrum sharing with other devices in a wireless network.

A medium access protocol shall be implemented by the equipment.

Test Equipment

Radiated Emission Measurement(RF)

Item	Equipment	Manufacturer	Model No.	Serial No.	Last Cal.	Cal. Interval
1.	Spectrum Analysis	Agilent	E4407B	US39390582	Aug. 09, 2013	1 Year
2.	Preamplifier	Instruments corporation	EMC011830	980100	Aug. 09, 2013	1 Year
3.	EMI Test Receiver	Rohde & Schwarz	ESPI	101604	Apr. 23, 2013	1 Year
4.	Double Ridged Horn Antenna	Instruments corporation	GTH-0118	351600	Aug. 09, 2013	3 Year
5.	Bilog Broadband Antenna	Schwarzbeck	VULB9163	VULB 9163-289	Apr. 23, 2013	3 Year
6.	Pre-amplifier	SONOMA	310N	186860	Apr. 23, 2013	1 Year
7.	EMI Test Software EZ-EMC	SHURPLE	N/A	N/A	N/A	N/A

Radiation Uncertainty : Ur = 4.3dB

Test Result

Environmental conditions:

Temperature	Relative Humidity	ATM Pressure
23°C	48%	1014 mbar

Complies

Pass

3.5 Transmitter Spurious Emissions

Standard Application

According to ETSI EN 300 328 V1.8.1, spurious emissions are emissions outside the frequency range as defined in frequency range. The level of spurious emissions shall be measured as:

- Either:
- a. Their power in a specified load (conducted spurious emissions);
 - and b. Their effective radiated power when radiated by the cabinet or structure of the equipment (cabinet radiation);
 - or c. Their effective radiated power when radiated by cabinet and antenna.

The spurious emissions of the transmitter shall not exceed the values in following tables

Limits EN 300 328, Clause 4.3.4.2

Frequency Range	Narrowband Spurious Emissions		Wideband Spurious Emissions	
	Limit When Operating	Limit When In Standby	Limit When Operating	Limit When In Standby
30 MHz ~ 1 GHz	-36 dBm	-57 dBm	-86 dBm/Hz	-107 dBm/Hz
Above 1 GHz ~ 12.75 GHz	-30 dBm	-47 dBm	-80 dBm/Hz	-97 dBm/Hz
1.8 GHz ~ 1.9 GHz 5.15 GHz ~ 5.3 GHz	-47 dBm	-47 dBm	-97 dBm/Hz	-97 dBm/Hz

Test Equipment

Radiated Emission Measurement(RF)

Item	Equipment	Manufacturer	Model No.	Serial No.	Last Cal.	Cal. Interval
1.	Spectrum Analysis	Agilent	E4407B	US39390582	Aug. 09, 2013	1 Year
2.	Preamplifier	Instruments corporation	EMC011830	980100	Aug. 09, 2013	1 Year
3.	EMI Test Receiver	Rohde & Schwarz	ESPI	101604	Apr. 23, 2013	1 Year
4.	Double Ridged Horn Antenna	Instruments corporation	GTH-0118	351600	Aug. 09, 2013	3 Year
5.	Bilog Broadband Antenna	Schwarzbeck	VULB9163	VULB 9163-289	Apr. 23, 2013	3 Year
6.	Pre-amplifier	SONOMA	310N	186860	Apr. 23, 2013	1 Year
7.	EMI Test Software EZ-EMC	SHURPLE	N/A	N/A	N/A	N/A

Radiation Uncertainty : Ur = 4.3dB

Test Procedure

Radiated measurements were performed with the aid of a test antenna and measurement instruments. The test antenna and measurement instrument shall be calibrated according to the procedure defined in this annex. The equipment to be measured and the test antenna shall be oriented to obtain the maximum emitted power level. This position was recorded in the measurement report. The frequency range was measured in this position.

Preferably, radiated measurements were performed in an anechoic chamber. For other test sites corrections may be needed. The following test procedure applies:

- f) a test site which fulfils the requirements of the specified frequency range of this measurement shall be used. The test antenna were oriented initially for vertical polarization unless otherwise stated and the transmitter under test shall be placed on the support in its standard position and switched on;
- g) for average power measurements a non-selective voltmeter or wide band spectrum analyzer were used. For other measurements a spectrum analyzer or selective voltmeter shall be used and tuned to the measurement frequency.

In either case a) or b), the test antenna shall be raised or lowered, if necessary, through the specified height range until the maximum signal level is detected on the spectrum analyzer or selective voltmeter.

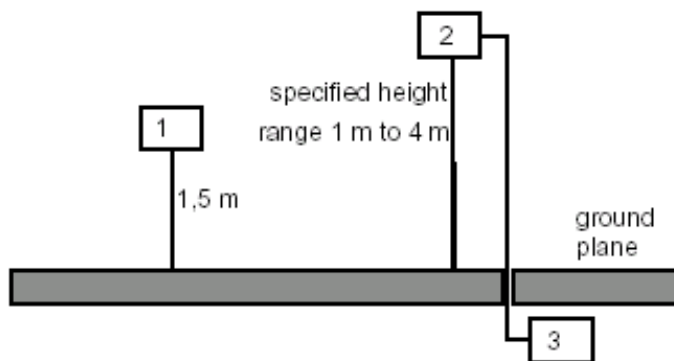

- 1) equipment under test.
- 2) test antenna.
- 3) spectrum analyser or measuring receiver.

Figure C.1: Measurement arrangement No.1

- h) the transmitter shall be rotated through 360° about a vertical axis until a higher maximum signal is received;
- i) the test antenna shall be raised or lowered again, if necessary, through the specified height range until a maximum is obtained. This level shall be recorded.

NOTE: This maximum may be a lower value than the value obtainable at heights outside the specified limits.

The test antenna need not be raised or lowered if the measurement is carried out on a test site according to clause b.1.2. This measurement shall be repeated for horizontal polarization.

The actual signal generated by the measured equipment may be determined by means of a substitution measurement in which a known signal source replaces the device to be measured, see figure C.2.

Preferably, this method of measurement shall be used in an anechoic chamber. For other test sites corrections may be needed.

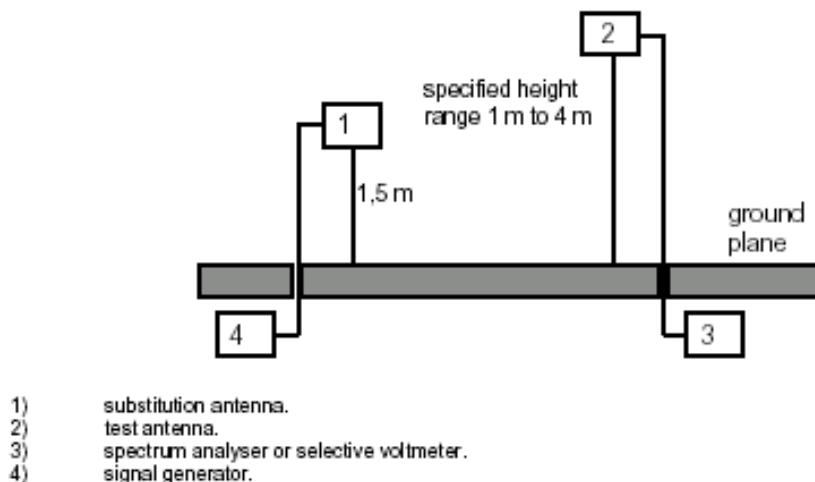

Figure C.2: Measurement arrangement No.2

e) using measurement arrangement NO.2, the substitution antenna shall replace the transmitter antenna in the same position and in vertical polarization. The frequency of the signal generator shall be adjusted to the measurement frequency. The test antenna shall be raised or lowered, if necessary, to ensure that the maximum signal is still received. The input signal to the substitution antenna shall be adjusted in level until an equal or a known related level to that detected from the transmitter is obtained in the test receiver;

- the radiated power is equal to the power supplied by the signal generator, increased by the known relationship if necessary and after corrections due to the gain of the substitution antenna and the cable loss between the signal generator and the substitution antenna;

f) this measurement shall be repeated with horizontal and vertical polarization.

TEST RESULTS

Below 1GHz (The worst case)

Test Mode: 802.11g(CH Low)

Tested by: Rock Zeng

Ambient temperature: 24°C

Relative humidity: 50 % RH

Date: Nov. 25, 2013

Frequency (MHz)	Antenn Polarization	S.G. (dBm)	Cable loss (dB)	Ant.Gain (dBi)	Emission level (dBm)	Limit (dBm)	Margin (dB)
62.520	V	-46.32	1.42	-8.72	-56.46	-36.00	-20.46
196.120	V	-48.20	1.53	-8.00	-57.73	-36.00	-21.73
297.030	V	-44.98	1.27	-8.58	-54.83	-36.00	-18.83
674.990	V	-46.43	2.01	-8.36	-56.80	-36.00	-20.80
800.340	V	-48.71	2.13	-8.71	-59.55	-36.00	-23.55
--							
193.390	H	-45.23	1.64	-10.35	-57.22	-36.00	-21.22
275.150	H	-43.16	1.93	-9.47	-54.56	-36.00	-18.56
393.620	H	-48.21	2.30	-8.96	-59.47	-36.00	-23.47
475.970	H	-45.89	2.41	-8.87	-57.17	-36.00	-21.17
895.430	H	-43.70	2.49	-8.56	-54.75	-36.00	-18.75
--							

Test Mode: 802.11g (CH High)

Tested by: Rock Zeng

Ambient temperature: 24°C

Relative humidity: 50 % RH

Date: Nov. 25, 2013

Frequency (MHz)	Antenna Polarization	S.G. (dBm)	Cable loss (dB)	Ant.Gain (dBi)	Emission level (dBm)	Limit (dBm)	Margin (dB)
99.230	V	-41.03	1.26	-10.21	-52.50	-36.00	-16.50
124.120	V	-41.39	1.75	-9.26	-52.40	-36.00	-16.40
291.300	V	-41.33	1.34	-10.24	-52.91	-36.00	-16.91
315.480	V	-41.01	2.21	-8.76	-51.98	-36.00	-15.98
502.190	V	-41.37	2.34	-10.34	-54.05	-36.00	-18.05
--							
152.550	H	-42.59	1.47	-8.40	-52.46	-36.00	-16.46
161.340	H	-43.32	1.56	-8.35	-53.23	-36.00	-17.23
365.120	H	-42.71	2.14	-8.90	-53.75	-36.00	-17.75
497.680	H	-41.26	2.23	-8.65	-52.14	-36.00	-16.14
927.020	H	-43.90	2.16	-10.50	-56.56	-36.00	-20.56
--							

Note:

1. The emission behaviour belongs to narrowband spurious emission.
2. Remark"---" means that the emission level is too low to be measured
3. Calculation of result is:
Emission Level (dBm) = Reading level (dBm) + Correction Factor (dB)

Above 1GHz (The worst case)

Test Mode: 802.11b(CH Low)

Tested by: Rock Zeng

Ambient temperature: 24°C

Relative humidity: 50 % RH

Date: Nov. 25, 2013

Frequency (MHz)	Antenn Polarization	S.G. (dBm)	Cable loss (dB)	Ant.Gain (dBi)	Emission level (dBm)	Limit (dBm)	Margin (dB)
4824	V	-50.06	2.40	11.0	-41.46	-30	-11.46
--							
4824	H	-51.95	2.35	11.0	-43.30	-30	-13.30
--							
--							

Test Mode: 802.11b(CH High)

Tested by: Rock Zeng

Ambient temperature: 24°C

Relative humidity: 50 % RH

Date: Nov. 25, 2013

Frequency (MHz)	Antenna Polarization	S.G. (dBm)	Cable loss (dB)	Ant.Gain (dBi)	Emission level (dBm)	Limit (dBm)	Margin (dB)
4944	V	-52.36	4.60	11.0	-45.96	-30	-15.96
--							
4944	H	-49.42	4.59	11.0	-43.01	-30	-13.01
--							

Note:

1. The emission behaviour belongs to narrowband spurious emission.
2. Remark"--" means that the emission level is too low to be measured
3. Calculation of result is:
Emission Level (dBm) = Reading level (dBm) + Correction Factor (dB)

3.6 Receiver Spurious Emissions

Standard Application

According to ETSI EN 300 328 V1.8.1

The spurious emissions of the receiver shall not exceed the values in following tables

Limits EN 300 328, Clause 4.3.5.2

Frequency Range	Narrowband Spurious Emissions	Wideband Spurious Emissions
30 MHz ~ 1 GHz	-57 dBm	-107 dBm/Hz
Above 1 GHz ~ 12.75 GHz	-47 dBm	-97 dBm/Hz

Test Equipment

Radiated Emission Measurement (RF)

Item	Equipment	Manufacturer	Model No.	Serial No.	Last Cal.	Cal. Interval
1.	Spectrum Analysis	Agilent	E4407B	US39390582	Aug. 09, 2013	1 Year
2.	Preamplifier	Instruments corporation	EMC011830	980100	Aug. 09, 2013	1 Year
3.	EMI Test Receiver	Rohde & Schwarz	ESPI	101604	Apr. 23, 2013	1 Year
4.	Double Ridged Horn Antenna	Instruments corporation	GTH-0118	351600	Aug. 09, 2013	3 Year
5.	Bilog Broadband Antenna	Schwarzbeck	VULB9163	VULB 9163-289	Apr. 23, 2013	3 Year
6.	Pre-amplifier	SONOMA	310N	186860	Apr. 23, 2013	1 Year
7.	EMI Test Software EZ-EMC	SHURPLE	N/A	N/A	N/A	N/A

Radiation Uncertainty : Ur = 4.3dB

Test Procedure

Same as Section 4.3.6. Transmitter Spurious Emissions except RX Operating

TEST RESULTS

Below 1GHz (The worst case)

Test Mode: 802.11g(CH Low)

Tested by: Rock Zeng

Ambient temperature: 24°C

Relative humidity: 50 % RH

Date: Nov. 25, 2013

Frequency (MHz)	Antenn Polarization	S.G. (dBm)	Cable loss (dB)	Ant.Gain (dBi)	Emission level (dBm)	Limit (dBm)	Margin (dB)
61.290	V	-53.06	1.24	-8.00	-62.30	-57	-5.30
191.450	V	-54.45	1.37	-8.05	-63.87	-57	-6.87
365.690	V	-56.11	1.92	-8.66	-66.69	-57	-9.69
595.520	V	-57.18	2.15	-9.57	-68.9	-57	-11.90
709.470	V	-58.24	2.38	-9.12	-69.74	-57	-12.74
--							
99.300	H	-55.29	1.33	-8.50	-65.12	-57	-8.12
209.320	H	-54.33	1.46	-8.42	-64.21	-57	-7.21
352.660	H	-56.03	1.68	-8.76	-66.47	-57	-9.47
502.490	H	-57.48	2.15	-9.51	-69.14	-57	-12.14
805.370	H	-58.25	2.62	-10.09	-70.96	-57	-13.96
--							

Test Mode: 802.11g (CH High)

Tested by: Rock Zeng

Ambient temperature: 24°C

Relative humidity: 50 % RH

Date: Nov. 25, 2013

Frequency (MHz)	Antenna Polarization	S.G. (dBm)	Cable loss (dB)	Ant.Gain (dBi)	Emission level (dBm)	Limit (dBm)	Margin (dB)
76.920	V	-55.06	1.25	-8.56	-64.87	-57	-7.87
150.650	V	-57.26	1.38	-8.72	-67.36	-57	-10.36
221.400	V	-57.09	1.49	-8.46	-67.04	-57	-10.04
452.870	V	-56.14	1.66	-8.38	-66.18	-57	-9.18
886.050	V	-57.09	1.25	-9.00	-67.34	-57	-10.34
--							
132.260	H	-65.67	1.24	-8.88	-75.79	-57	-18.79
245.130	H	-54.05	1.42	-8.57	-64.04	-57	-7.04
461.220	H	-62.11	1.66	-8.22	-71.99	-57	-14.99
514.630	H	-61.85	1.80	-9.35	-73.00	-57	-16.00
879.410	H	-57.33	1.55	-10.27	-69.15	-57	-12.15
--							

Note:

1. The emission behaviour belongs to narrowband spurious emission.
2. Remark"---" means that the emission level is too low to be measured
3. Calculation of result is:
Emission Level (dBm) = Reading level (dBm) + Correction Factor (dB)

Above 1GHz (The worst case)

Test Mode: 802.11b(CH Low)

Tested by: Rock Zeng

Ambient temperature: 24°C

Relative humidity: 50 % RH

Date: Nov. 25, 2013

Frequency (MHz)	Antenn Polarization	S.G. (dBm)	Cable loss (dB)	Ant.Gain (dBi)	Emission level (dBm)	Limit (dBm)	Margin (dB)
4824	V	-58.77	8.05	10.45	-56.37	-47	-9.37
--							
4824	H	-56.55	8.05	10.45	-54.15	-47	-7.15
--							
--							

Test Mode: 802.11b(CH High)

Tested by: Rock Zeng

Ambient temperature: 24°C

Relative humidity: 50 % RH

Date: Nov. 25, 2013

Frequency (MHz)	Antenna Polarization	S.G. (dBm)	Cable loss (dB)	Ant.Gain (dBi)	Emission level (dBm)	Limit (dBm)	Margin (dB)
4944	V	-61.09	6.90	9.50	-58.49	-47	-11.49
--							
4944	H	-59.32	6.90	9.50	-56.72	-47	-9.72
--							

Note:

1. The emission behaviour belongs to narrowband spurious emission.
2. Remark"---" means that the emission level is too low to be measured
3. Calculation of result is:
Emission Level (dBm) = Reading level (dBm) + Correction Factor (dB)

APPENDIX I (TEST PHOTOGRAPHS)

1. Photo of Emission Test

