

RED-Radio Test Report

For

Shanghai High-Flying Electronics Technology Co., Ltd

WI-FI Module

Model No.: HF-LPB120

Prepared For : Shanghai High-Flying Electronics Technology Co., Ltd
Address : Room 1002, #1 Building A, No.3000 Longdong Avenue, Pudong,
Shanghai, China

Prepared By : Shenzhen Anbotek Compliance Laboratory Limited
Address : 1/F., Building 1, SEC Industrial Park, No.0409 Qianhai Road, Nanshan
District, Shenzhen, Guangdong, China
Tel: (86) 755-26066544 Fax: (86) 755-26014772

Report Number : R0217060216W
Date of Test : Jul. 17~26, 2017
Date of Report : Jul. 28, 2017

Contents

1. General Information.....	5
1.1. Client Information.....	5
1.2. Description of Device (EUT).....	5
1.3. Auxiliary Equipment Used During Test.....	5
1.4. Description of Test Modes.....	6
1.5. List of channels.....	8
1.6. Test Conditions.....	8
1.7. Test Equipment List.....	9
1.8. Measurement Uncertainty.....	10
1.9. Description of Test Facility.....	10
2. Summary of Test Results.....	11
3. RF Output Power.....	12
3.1. RF Output Power Limit.....	12
3.2. Test Setup.....	12
3.3. Test Procedure.....	12
3.4. Test Data.....	12
4. Power Spectral Density.....	15
4.1. Test Limit.....	15
4.2. Test Setup.....	15
4.3. Test Procedure.....	15
4.4. Test Data.....	15
5. Adaptivity.....	17
5.1. Test Limit.....	17
5.2. Test Setup.....	18
5.3. Test Procedure.....	18
5.4. Test Data.....	18
6. Occupied Channel Bandwidth.....	19
6.1. Test Limit.....	19
6.2. Test Setup.....	19
6.3. Test Procedure.....	19
6.4. Test Data.....	19
7. Transmitter Unwanted Emissions in the out-of-band Domain.....	21
7.1. Test Limit.....	21
7.2. Test Setup.....	21
7.3. Test Procedure.....	21
7.4. Test Data.....	22
8. Transmitter Unwanted Emissions in the Spurious Domain.....	24
8.1. Test Limit.....	24
8.2. Test Setup.....	24
8.3. Test Procedure.....	24
8.4. Test Data.....	25
9. Receiver Spurious Emissions.....	26

9.1. Test Limit.....	26
9.2. Test Setup.....	26
9.3. Test Procedure.....	26
9.4. Test Data.....	27
10. Receiver Blocking.....	28
10.1. Test Limit.....	28
10.2. Test Setup.....	29
10.3. Test Procedure.....	29
10.4. Minimum Performance Declaration.....	29
10.5. Test Data.....	30
APPENDIX I -- TEST SETUP PHOTOGRAPH.....	31

Anbotek

TEST REPORT

Applicant : Shanghai High-Flying Electronics Technology Co., Ltd
Manufacturer : Shanghai High-Flying Electronics Technology Co., Ltd
Product Name : WI-FI Module
Model No. : HF-LPB120
Trade Mark : High-Flying
Rating(s) : Input DC 3.3V, 170~300mA

Test Standard(s) : ETSI EN 300 328 V2.1.1 (2016-11)

The device described above is tested by Shenzhen Anbotek Compliance Laboratory Limited to determine the maximum emission levels emanating from the device and the severe levels of the device can endure and its performance criterion. The measurement results are contained in this test report and Shenzhen Anbotek Compliance Laboratory Limited is assumed full of responsibility for the accuracy and completeness of these measurements. Also, this report shows that the EUT (Equipment Under Test) is technically compliant with the ETSI EN 300 328 V2.1.1 requirements.

This report applies to above tested sample only and shall not be reproduced in part without written approval of Shenzhen Anbotek Compliance Laboratory Limited.

Date of Test : Jul. 17~26, 2017

Prepared By :



Winkey Wang

(Engineer / Winkey Wang)

Reviewer :

May Lu

(Project Manager / May Lu)

Approved & Authorized Signer :

Tom Chen

(Manager / Tom Chen)

1. General Information

1.1. Client Information

Applicant	:	Shanghai High-Flying Electronics Technology Co., Ltd
Address	:	Room 1002, #1 Building A, No.3000 Longdong Avenue, Pudong, Shanghai, China
Manufacturer	:	Shanghai High-Flying Electronics Technology Co., Ltd
Address	:	Room 1002, #1 Building A, No.3000 Longdong Avenue, Pudong, Shanghai, China

1.2. Description of Device (EUT)

Product Name	:	WI-FI Module	
Model No.	:	HF-LPB120	
Trade Mark	:	High-Flying	
Test Power Supply	:	AC 230V, 50Hz for adapter	
Product Description	:	Operation Frequency:	2412MHz ~ 2472MHz
		Transfer Rate:	802.11b:11/5.5/2/1Mbps
			802.11g:54/48/36/24/18/12/9/6 Mbps
			802.11n: up to 150Mbps
		Number of Channel:	13 Channels
		Modulation Technology:	DSSS, OFDM
		Modulation Type:	CCK, DQPSK, DBPSK for DSSS
64QAM, 16QAM, QPSK, BPSK for OFDM			
Antenna Type:	PCB Antenna		
Antenna Gain(Peak):	2 dBi		
<p>Remark: 1) For a more detailed features description, please refer to the manufacturer's specifications or the User's Manual. 2)This report is for WiFi</p>			

1.3. Auxiliary Equipment Used During Test

Adapter	:	M/N: FLD052-0501000C Input: AC 100-240V, 50/60Hz, 0.15A Max Output: DC 5.0V, 1.0A
---------	---	---

1.4. Description of Test Modes

Pre-Scan has been conducted to determine the worst-case mode from all possible combinations between available modulations, data rates and antenna ports (if EUT with antenna diversity architecture).

Following channel(s) was (were) selected for the final test as listed below.

RF Output Power Test

Mode	Available Channel	Tested Channel	Modulation Technology	Modulation Type	Data Rate (Mbps)
802.11b	1 to 13	1, 7, 13	DSSS	DBPSK	1.0
802.11g	1 to 13	1, 7, 13	OFDM	BPSK	6.0
802.11n (HT20)	1 to 13	1, 7, 13	OFDM	BPSK	6.5

Power Spectral Density Test

Mode	Available Channel	Tested Channel	Modulation Technology	Modulation Type	Data Rate (Mbps)
802.11b	1 to 13	1, 7, 13	DSSS	DBPSK	1.0
802.11g	1 to 13	1, 7, 13	OFDM	BPSK	6.0
802.11n (HT20)	1 to 13	1, 7, 13	OFDM	BPSK	6.5

Adaptivity Test:

Mode	Available Channel	Tested Channel	Modulation Technology
802.11b	1 to 13	1, 13	DSSS
802.11g	1 to 13	1, 13	OFDM
802.11n (HT20)	1 to 13	1, 13	OFDM

Occupied Channel Bandwidth Test

Mode	Available Channel	Tested Channel	Modulation Technology	Modulation Type	Data Rate (Mbps)
802.11b	1 to 13	1, 13	DSSS	DBPSK	1.0
802.11g	1 to 13	1, 13	OFDM	BPSK	6.0
802.11n (HT20)	1 to 13	1, 13	OFDM	BPSK	6.5

Transmitte unwanted emissioin in the out-of-band domain Test

Mode	Available Channel	Tested Channel	Modulation Technology	Modulation Type	Data Rate (Mbps)
802.11b	1 to 13	1, 13	DSSS	DBPSK	1.0
802.11g	1 to 13	1, 13	OFDM	BPSK	6.0
802.11n (HT20)	1 to 13	1, 13	OFDM	BPSK	6.5

Spurious Emissions Test

Mode	Available Channel	Tested Channel	Modulation Technology	Modulation Type	Data Rate (Mbps)
802.11b	1 to 13	13	DSSS	DBPSK	1

Receiver Blocking Test

Mode	Available Channel	Tested Channel	Modulation Technology
802.11b	1 to 13	1, 13	DSSS
802.11g	1 to 13	1, 13	OFDM
802.11n (HT20)	1 to 13	1, 13	OFDM

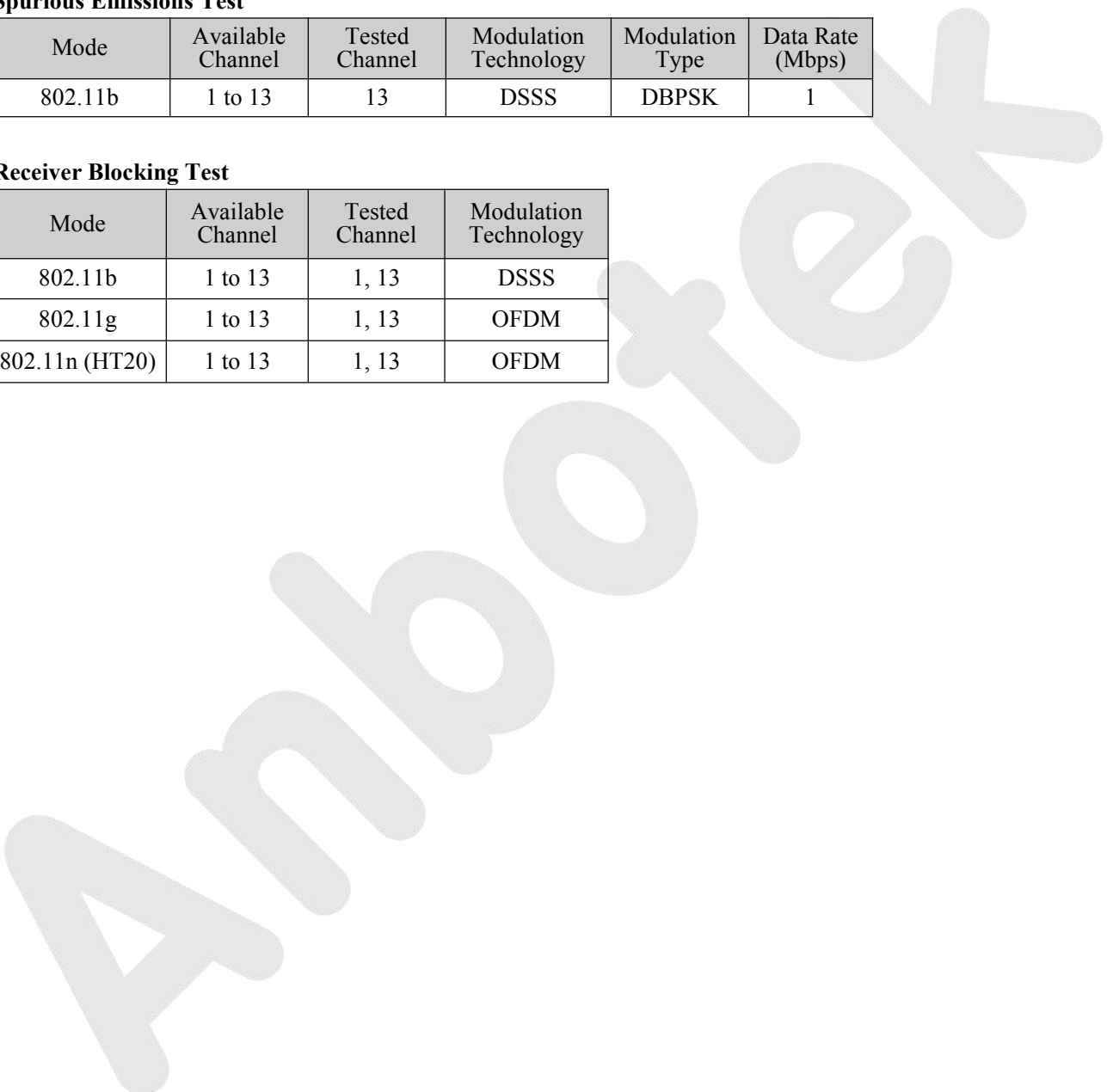

1.5. List of channels

Thirteen channels are provided for 802.11b, 802.11g, 802.11n(HT20):

Channel	Frequency	Channel	Frequency
1	2412 MHz	8	2447 MHz
2	2417 MHz	9	2452 MHz
3	2422 MHz	10	2457 MHz
4	2427 MHz	11	2462 MHz
5	2432 MHz	12	2467 MHz
6	2437 MHz	13	2472 MHz
7	2442 MHz		

1.6. Test Conditions

	Normal Test Conditions	Extreme Test Conditions
Temperature	15°C - 35°C	-20°C ~ 55°C Note: (1)
Relative Humidity	20% - 75%	N/A
Supply Voltage	AC 230V, 50Hz for adapter	N/A

Note: (1) The HT 55°C and LT -20°C was declared by manufacturer, The EUT couldn't be operate normally with higher or lower temperature.

1.7. Test Equipment List

Item	Equipment	Manufacturer	Model No.	Serial No.	Last Cal.	Cal. Interval
1.	Spectrum Analysis	Agilent	E4407B	US39390582	May 27, 2017	1 Year
2.	Preamplifier	SKET Electronic	BK1G18G30 D	KD17503	May 27, 2017	1 Year
3.	EMI Test Receiver	Rohde & Schwarz	ESPI	101604	May 27, 2017	1 Year
4.	Double Ridged Horn Antenna	Instruments corporation	GTH-0118	351600	May 31, 2017	1 Year
5.	Bilog Broadband Antenna	Schwarzbeck	VULB9163	VULB 9163-289	May 31, 2017	1 Year
6.	Pre-amplifier	SONOMA	310N	186860	May 27, 2017	1 Year
7.	EMI Test Software EZ-EMC	SHURPLE	N/A	N/A	N/A	N/A
8.	MXA Spectrum Analysis	Agilent	N9020A	MY51170037	May 27, 2017	1 Year
9.	MXG RF Vector Signal Generator	Agilent	N5182A	MY48180656	May 27, 2017	1 Year
10.	DC Power supply	IVYTECH	IV6003	1601D6030007	May 26, 2017	1 Year
11.	TEMP&HUMI PROGRAMMABLE CHAMBER	Sertep	ZJ-HWHS8 0B	ZJ-17042804	Mar. 3, 2017	1 Year
12.	Universal Radio Communication Tester	Rohde & Schwarz	CMU 200	117888	May 27, 2017	1 Year
13.	Wideband Radio Communication Tester	Rohde & Schwarz	CMU 500	1201.0002K50- 104209-JC	May 27, 2017	1 Year
14.	High-Pass Filter	CDKMV	ZHPF-BM11 00 -4000-0730	B2015094550	May 27, 2017	1 Year
15.	High-Pass Filter	CDKMV	ZHPF-M3.5 -18G-3834	1307006523	May 27, 2017	1 Year
16.	4 Ch. Simultaneous Sampling 14 Bits 2 MS/s	Agilent	U2531A	TW54063507	May 27, 2017	1 Year
17.	4 Ch. Simultaneous Sampling 14 Bits 2 MS/s	Agilent	U2531A	TW54063513	May 27, 2017	1 Year

1.8. Measurement Uncertainty

For the test methods, according to ETSI EN 300 328 standard, the measurement uncertainty figures shall be calculated in accordance with ETR 100 028-1 [4] and shall correspond to an expansion factor (coverage factor) $k = 1,96$ or $k = 2$ (which provide confidence levels of respectively 95 % and 95, 45 % in the case where the distributions characterizing the actual measurement uncertainties are normal (Gaussian)).

Maximum measurement uncertainty

Parameter	Uncertainty
Occupied Channel Bandwidth	±5 %
RF output power, conducted	±1,5 dB
Power Spectral Density, conducted	±3 dB
Unwanted Emissions, conducted	±3 dB
All emissions, radiated	±6 dB
Temperature	±1 °C
Humidity	±5 %
DC and low frequency voltages	±3 %
Time	±5 %
Duty Cycle	±5 %

1.9. Description of Test Facility

The test facility is recognized, certified, or accredited by the following organizations:

FCC-Registration No.: 752021

Shenzhen Anbotek Compliance Laboratory Limited, EMC Laboratory has been registered and fully described in a report filed with the (FCC) Federal Communications Commission. The acceptance letter from the FCC is maintained in our files. Registration 752021, July 06, 2016.

ISED-Registration No.: 8058A-1

Shenzhen Anbotek Compliance Laboratory Limited, EMC Laboratory has been registered and fully described in a report filed with the (ISED) Innovation, Science and Economic Development Canada. The acceptance letter from the ISED is maintained in our files. Registration 8058A-1, June 13, 2016.

Test Location

All Emissions tests were performed at

Shenzhen Anbotek Compliance Laboratory Limited.

1/F., Building 1, SEC Industrial Park, No.0409 Qianhai Road, Nanshan District, Shenzhen, Guangdong, China

2. Summary of Test Results

List of Measurements			
No	Test Items	Clause No.	Results
Transmitter Items			
1	RF Output Power	4.3.2.2	Complies
2	Power Spectral Density	4.3.2.3	Complies
3	Duty Cycle, TX-Sequence, TX-gap	4.3.2.4	N/A Note (2)(3)
4	Medium Utilization (MU) factor	4.3.2.5	N/A Note (2)(3)
5	Adaptivity	4.3.2.6	N/A
6	Occupied Channel Bandwidth	4.3.2.7	Complies
7	Transmitter Unwanted Emissions in the Out-Of-Band Domain	4.3.2.8	Complies
8	Transmitter Unwanted Emissions in the Spurious Domain	4.3.2.9	Complies
Receiver Items			
10	Receiver spurious emissions	4.3.1.11	Complies
11	Receiver Blocking	4.3.2.12	Complies
<p>Note:</p> <p>(1) "N/A": indicates test is not applicable in this Test Report.</p> <p>(2) This requirement does not apply for equipment with a maximum declared RF Output power level of less than 10 dBm e.i.r.p. for equipment when operating in a mode where the RF Output power is less than 10 dBm e.i.r.p.</p> <p>(3) This requirement applies to non-adaptive equipment or to adaptive equipment when operating in a non-adaptive mode.</p> <p>(4) This requirement does not apply to adaptive equipment unless operating in non-adaptive mode.</p>			

3. RF Output Power

3.1. RF Output Power Limit

Condition	Limit
<input type="checkbox"/> Non-adaptive frequency hopping systems	Equal to or less than the value declared by the manufacturer. This declared value shall be equal to or less than 20 dBm.
<input checked="" type="checkbox"/> Adaptive frequency hopping systems	20dBm

3.2. Test Setup

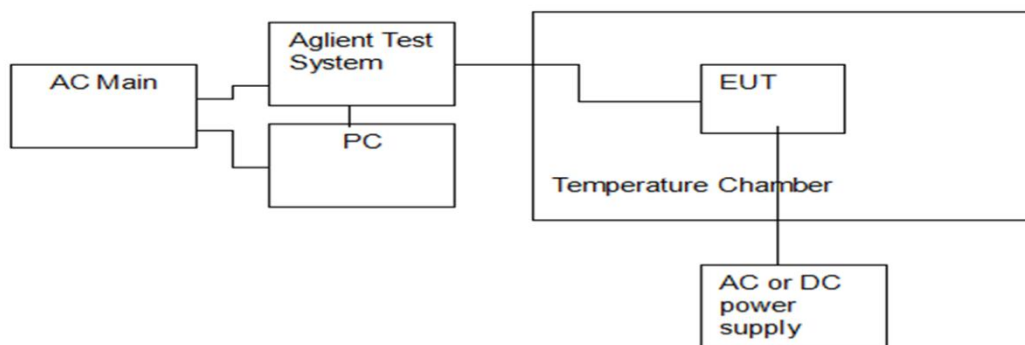

3.3. Test Procedure

Refer to chapter 5.4.2.2.1 of EN 300 328 V2.1.1.

1. Run a test program to control EUT transmitting at specific channel
2. Connect the power sensor to the transmit port
3. Power Meter was setting as below:
Sample speed: 1 MS/s
Number of bursts: at least 10bursts
Detector: RMS
4. A power meter was used to read the response of the power sensor
5. Define Start time and Stop time of a burst by 30dB below the highest value of the stores samples.
6. Find the highest burst value
7. Record the power level
8. EIRP = antenna gain + power level of step 7.

3.4. Test Data

Please to see the following pages

Temperature:	25° C	Relative Humidity:	60 %
Pressure:	1012 hPa	Test Voltage:	AC 230V, 50Hz for adapter

Test Mode:		TX(CH01/CH07/CH13)-802.11b				
TEST CONDITIONS				Total e.i.r.p (dBm)		
				CH00	CH07	CH13
T nom (°C)	20.00	V nom (V)	AC 230V	15.89	15.67	16.11
T min (°C)	-20.00	V nom (V)	AC 230V	15.82	15.65	16.13
T max (°C)	55.00	V nom (V)	AC 230V	15.90	15.61	16.09
Max RF Power				16.13		
Limits				20dBm		
Result				Complies		
Note: Power measurement, actual measurement for 16 Burst power.						

Test Mode:		TX(CH01/CH07/CH13)-802.11g				
TEST CONDITIONS				Total e.i.r.p (dBm)		
				CH00	CH07	CH13
T nom (°C)	20.00	V nom (V)	AC 230V	13.69	13.97	14.53
T min (°C)	-20.00	V nom (V)	AC 230V	13.63	13.89	14.57
T max (°C)	55.00	V nom (V)	AC 230V	13.67	13.92	14.50
Max RF Power				14.57		
Limits				20dBm		
Result				Complies		
Note: Power measurement, actual measurement for 16 Burst power.						

Test Mode:				TX(CH01/CH7/CH13)-802.11n(HT20)		
TEST CONDITIONS				Total e.i.r.p (dBm)		
				CH00	CH07	CH13
T nom (°C)	20.00	V nom (V)	AC 230V	13.01	12.98	12.76
T min (°C)	-20.00	V nom (V)	AC 230V	13.06	13.01	12.71
T max (°C)	55.00	V nom (V)	AC 230V	13.04	13.03	12.79
Max RF Power				13.06		
Limits				20dBm		
Result				Complies		
Note: Power measurement, actual measurement for 16 Burst power.						

Anbotek

4. Power Spectral Density

4.1. Test Limit

Condition	Frequency BAND	Limit (e.i.r.p.)
Under normal conditions	2400 ~ 2483.5 MHz	10dBm / 1MHz

4.2. Test Setup

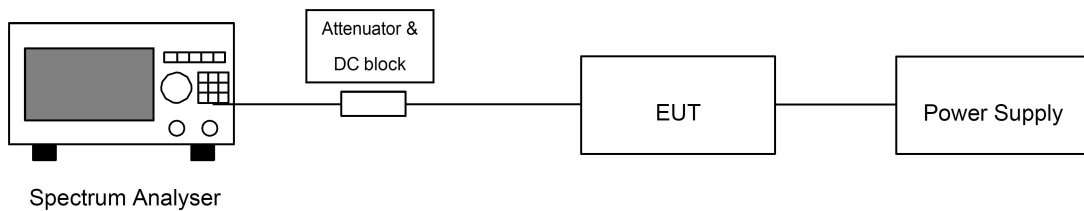

4.3. Test Procedure

Refer to ETSI EN 300 328 V2.1.1 (2016-11) Clause 5.4.3.

Connect the UUT to the spectrum analyzer and use the following settings:

Frequency range	2400MHz-2483.5MHz
RBW/VBW	10kHz/30kHz
Sweep points/time	>8350 / 10S
Detector	RMS
Trace	Max hold

4.4. Test Data

Temperature:	25° C	Relative Humidity:	60 %
Pressure:	1012 hPa	Test Voltage:	AC 230V, 50Hz for adapter

Channel	Channel Frequency (MHz)	Power Density (dBm/1MHz) (E.I.R.P)	Limit (dBm/1MHz) (E.I.R.P)	Test Result
802.11b				
01	2412.00	-0.281	10	PASS
07	2442.00	-0.146	10	PASS
13	2472.00	-0.583	10	PASS
802.11g				
01	2412.00	1.059	10	PASS
07	2442.00	0.795	10	PASS
13	2472.00	0.687	10	PASS

Channel	Channel Frequency (MHz)	Power Density (dBm/1MHz) (E.I.R.P)	Limit (dBm/1MHz) (E.I.R.P)	Test Result
802.11n(HT20)				
01	2412.00	1.558	10	PASS
07	2442.00	1.757	10	PASS
13	2472.00	2.436	10	PASS

Anbotek

5. Adaptivity

5.1. Test Limit

See clause 5.1 for the test conditions. These measurements shall only be performed at normal test conditions.

When supported by the operating frequency range of the equipment, this test shall be performed on two operating (hopping) frequencies randomly selected from the operating frequencies used by the equipment. The first (lower) frequency shall be randomly selected within the range 2 400 MHz to 2 442 MHz while the second (higher) frequency shall be randomly selected within the range 2 442 MHz to 2 483,5 MHz. The equipment shall be in a normal operating (hopping) mode.

For equipment which can operate in an adaptive and a non-adaptive mode, it shall be verified that prior to the test, the equipment is operating in the adaptive mode.

The equipment shall be configured in a mode that results in the longest Channel Occupancy Time.

<p>Non-LBT based Detect and Avoid:</p> <ol style="list-style-type: none"> 1 The frequency shall remain unavailable for a minimum time equal to 1 second after which the channel maybe considered again as an 'available' channel; 2 COT \leq 40 ms; 3 Idle Period = 5% of COT; 4 Detection threshold level = $-70\text{dBm/MHz} + 10 \cdot \log(100\text{mW/Pout})$ (Pout in mW E.I.R.P)
<p>LBT based Detect and Avoid (Frame Based Equipment):</p> <ol style="list-style-type: none"> 1 Minimum Clear Channel Assessment (CCA) time \leq 18 us; 2 CCA observation time declared by the supplier; 3 COT = 1~10 ms; 4 Idle Period \geq 5% of COT; 5 Detection threshold level = $-70\text{dBm/MHz} + 10 \cdot \log(100\text{mW/Pout})$ (Pout in mW E.I.R.P)
<p>LBT based Detect and Avoid (Load Based Equipment):</p> <ol style="list-style-type: none"> 1 Minimum Clear Channel Assessment (CCA) time \geq 18 us; 2 CCA declared by the manufacturer; 3 Detection threshold level = $-70\text{dBm/MHz} + 10 \cdot \log(100\text{mW/Pout})$ (Pout in mW E.I.R.P)
<p>Short Control Signalling Transmissions:</p> <p>Short Control Signalling Transmissions shall have a maximum duty cycle of 10% within any bservation period of 50ms.</p>

5.2. Test Setup

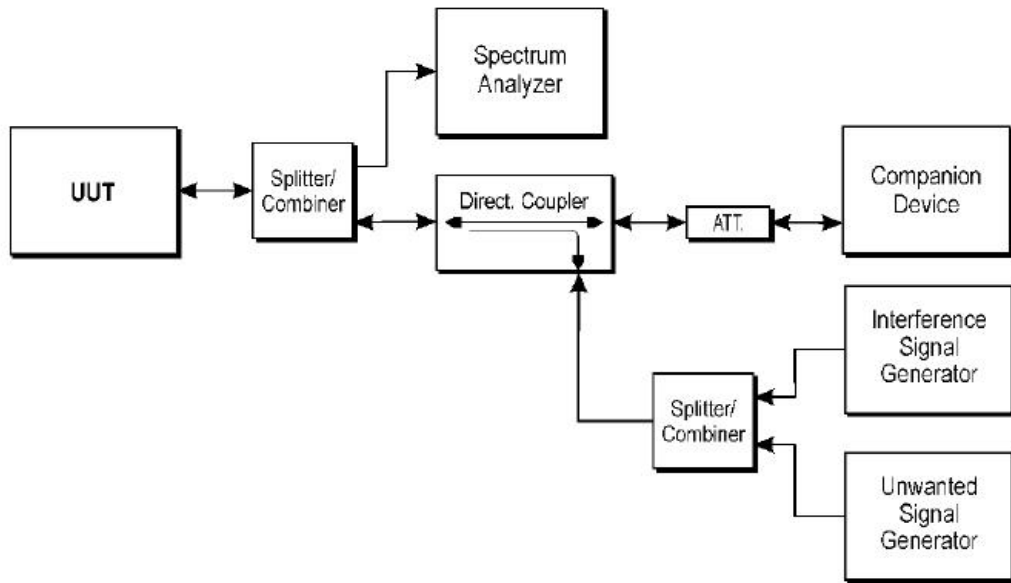

5.3. Test Procedure

Refer to ETSI EN 300 328 V2.1.1 (2016-11) Clause 5.4.6

5.4. Test Data

Note: The EUT is a Load Based Equipment.

Test Mode	Test Channel	Interference Signal Level(dBm)	Unwanted Signal Level(dBm)	Max. COT (ms)	Conclusion
802.11b	Lowest	-66.13	-35	3.13	Pass
	Highest	-66.13	-35	3.24	Pass
802.11g	Lowest	-64.57	-35	2.74	Pass
	Highest	-64.57	-35	2.96	Pass
802.11n(HT20)	Lowest	-63.06	-35	2.31	Pass
	Highest	-63.06	-35	2.85	Pass

6. Occupied Channel Bandwidth

6.1. Test Limit

Condition		Limit
All types of equipment		Shall fall completely within the band 2400 to 2483.5 MHz.
Additional requirement	For non-adaptive using wide band modulations other than FHSS system and e.i.r.p > 10dBm.	Less than 20MHz
	For non-adaptive Frequency Hopping system and e.i.r.p > 10dBm.	Less than 5MHz

6.2. Test Setup

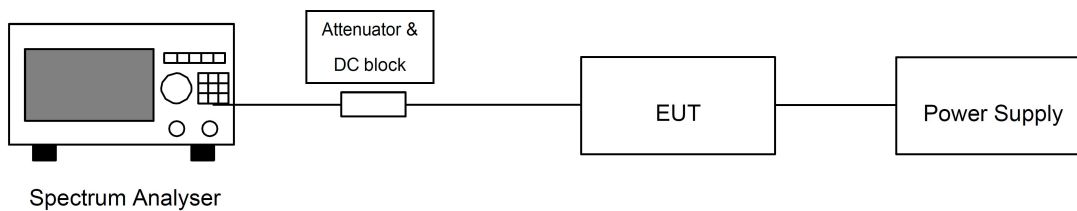

6.3. Test Procedure

Refer to EN 300 328, clause 5.4.7 for the test conditions and the measurement method.

The setting of the Spectrum Analyzer

Center Frequency	The centre frequency of the channel under test
Frequency Span	2 × Nominal Channel Bandwidth (e.g. 2MHz for BT)
Detector	RMS
RBW	~ 1 % of the span without going below 1 % (62KHz)
VBW	3 × RBW (180KHz)
Trace	Max hold
Sweep time	1S

6.4. Test Data

EUT:		Model Name:	
Temperature:	25° C	Relative Humidity:	60 %
Pressure:	1012 hPa	Test Voltage:	AC 230V, 50Hz for adapter

Test Channel	99% Bandwidth (MHz)	FL/FH (MHz)	Limit	Result
802.11b				
Lowest	12.464	2405.19	2400MHz ~	PASS
Highest	12.263	2478.86	2483.5MHz	PASS
802.11g				
Lowest	17.459	2403.63	2400MHz ~	PASS
Highest	16.774	2480.24	2483.5MHz	PASS
802.11n(HT20)				
Lowest	17.996	2403.06	2400MHz ~	PASS
Highest	18.463	2480.77	2483.5MHz	PASS

Anbotek

7. Transmitter Unwanted Emissions in the out-of-band Domain

7.1. Test Limit

The transmitter unwanted emissions in the out-of-band domain but outside the allocated band, shall not exceed the values provided by the mask in figure as below.

Note: Within the 2400MHz to 2483.5MHz band, the Out-of band emissions are fulfilled by compliance with the Occupied Channel Bandwidth requirement in clause 4.3.2.6.

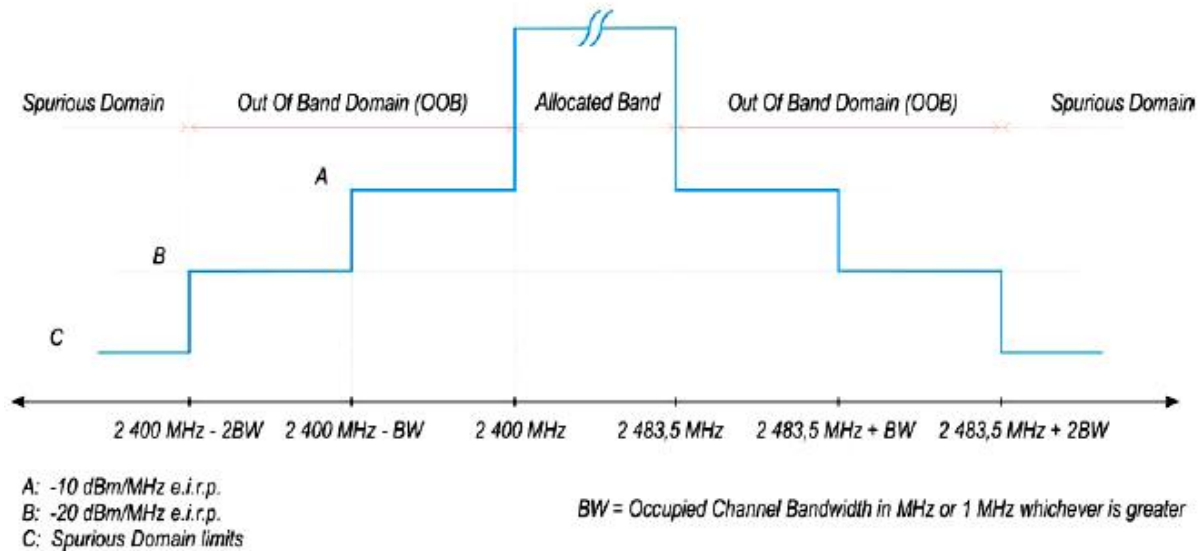

7.2. Test Setup

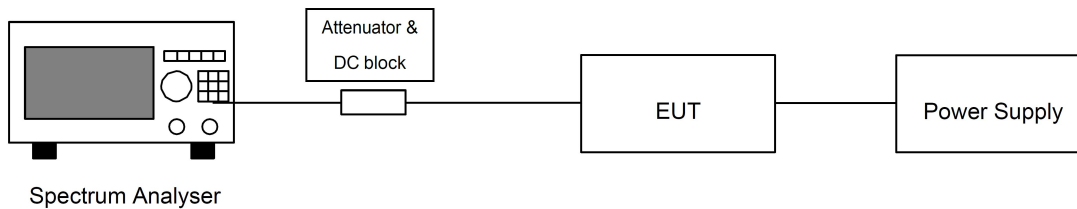

7.3. Test Procedure

Refer as EN 300 328, clause 5.4.8 for the test conditions and the measurement method.

The setting of the Spectrum Analyzer

RBW/ VBW	1MHz/3MHz
Span	0Hz
Filter mode	Channel filter
Sweep mode	Continuous
Sweep Points	Sweep Time[s]/(1us) or 5000 points, whichever is greater
Detector	RMS
Trace mode	Max Hold
Trigger Mode	Video trigger

7.4. Test Data

Temperature:	25° C	Relative Humidity:	60 %
Pressure:	1012 hPa	Test Voltage:	AC 230V, 50Hz for adapter

Mode: 802.11b

Channel frequency		2412MHz		2472MHz	
Test condition		OOB Emission(MHz)		OOB Emission(MHz)	
		2400-BW ~2400	2400-2BW ~2400-BW	2483.5 ~ 2483.5+BW	2483.5+BW ~ 2483.5+2BW
		Maximum power (dBm)	Maximum power (dBm)	Maximum power (dBm)	Maximum power (dBm)
V nom (V)	AC 230V	-34.65	-56.32	-33.42	-51.14
Limits		-10.00	-20.00	-10.00	-20.00
PASS/FAIL		PASS	PASS	PASS	PASS

Mode: 802.11g

Channel frequency		2412MHz		2472MHz	
Test condition		OOB Emission(MHz)		OOB Emission(MHz)	
		2400-BW ~2400	2400-2BW ~2400-BW	2483.5 ~ 2483.5+BW	2483.5+BW ~ 2483.5+2BW
		Maximum power (dBm)	Maximum power (dBm)	Maximum power (dBm)	Maximum power (dBm)
V nom (V)	AC 230V	-55.41	-62.63	-45.48	-58.59
Limits		-10.00	-20.00	-10.00	-20.00
PASS/FAIL		PASS	PASS	PASS	PASS

Mode: 802.11n(HT20)

Channel frequency		2412MHz		2472MHz	
Test condition		OOB Emission(MHz)		OOB Emission(MHz)	
		2400-BW ~2400	2400-2BW ~2400-BW	2483.5 ~ 2483.5+BW	2483.5+BW ~ 2483.5+2BW
		Maximum power (dBm)	Maximum power (dBm)	Maximum power (dBm)	Maximum power (dBm)
V nom (V)	AC 230V	-54.27	-63.44	-44.36	-58.27
Limits		-10.00	-20.00	-10.00	-20.00
PASS/FAIL		PASS	PASS	PASS	PASS

Anbotek

8. Transmitter Unwanted Emissions in the Spurious Domain

8.1. Test Limit

Frequency Range	Maximum Power	Bandwidth
30 MHz to 47 MHz	-36dBm	100kHz
47 MHz to 74 MHz	-54dBm	100kHz
74 MHz to 87,5 MHz	-36dBm	100kHz
87,5 MHz to 118 MHz	-54dBm	100kHz
118 MHz to 174 MHz	-36dBm	100kHz
174 MHz to 230 MHz	-54dBm	100kHz
230 MHz to 470 MHz	-36dBm	100kHz
470 MHz to 862 MHz	-54dBm	100kHz
862 MHz to 1 GHz	-36dBm	100kHz
1GHz ~ 12.75GHz	-30dBm	1MHz

8.2. Test Setup

(A) Radiated Emission Test Set-Up Frequency Bellow 1 GHz.

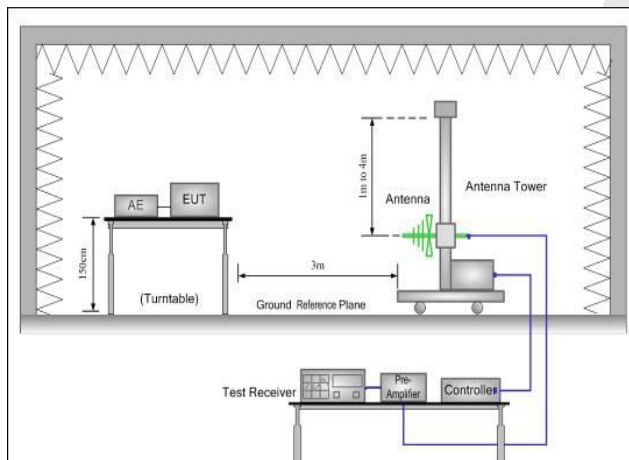

(B) Radiated Emission Test Set-Up Frequency Above 1 GHz

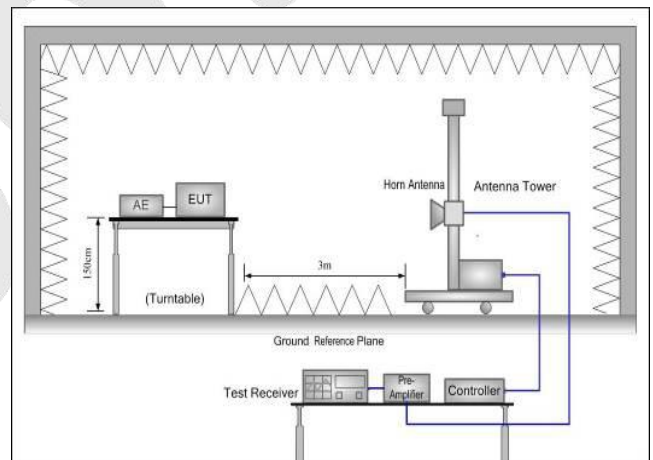

8.3. Test Procedure

Refer to chapter 5.4.9.2.2 of EN 300 328 V2.1.1 for radiated measurement.

1. For the actual test configuration, please refer to the related Item in this test report (Photographs of the Test Configuration).
2. The measurements were performed when normal hopping was disabled. In this case measurements were performed when operating at the lowest and the highest hopping frequency.
3. The equipment was configured to operate under its worst case situation with respect to output power.
4. The test setup has been constructed as the normal use condition. Controlling software has been activated to set the EUT on specific status.

8.4. Test Data

Temperature:	25° C	Relative Humidity:	60 %
Pressure:	1012 hPa	Test Voltage:	AC 230V, 50Hz for adapter

The low channel					
Frequency (MHz)	Level(dBm)	Limit (dBm)	Margin(dB)	Polarization	Test Result
57.76	-73.93	-54.00	-19.93	H	PASS
133.55	-65.22	-36.00	-29.22	H	
373.11	-70.95	-36.00	-34.95	H	
698.77	-73.61	-54.00	-19.61	H	
4824.93	-61.27	-30.00	-31.27	H	
7236.72	-63.61	-30.00	-33.61	H	
60.62	-72.90	-54.00	-18.90	V	
131.11	-67.11	-36.00	-31.11	V	
331.77	-66.79	-36.00	-30.79	V	
741.58	-67.95	-54.00	-13.95	V	
4824.66	-61.53	-30.00	-31.53	V	
7236.71	-64.90	-30.00	-34.90	V	

The high channel					
Frequency (MHz)	Level(dBm)	Limit (dBm)	Margin(dB)	Polarization	Test Result
58.16	-65.89	-54.00	-11.89	H	PASS
163.98	-68.50	-36.00	-32.50	H	
443.69	-69.12	-36.00	-33.12	H	
666.42	-74.07	-54.00	-20.07	H	
4944.06	-61.91	-30.00	-31.91	H	
7416.46	-63.79	-30.00	-33.79	H	
67.32	-72.22	-54.00	-18.22	V	
137.11	-68.53	-36.00	-32.53	V	
256.38	-66.64	-36.00	-30.64	V	
648.92	-71.08	-54.00	-17.08	V	
4944.10	-57.90	-30.00	-27.90	V	
7416.20	-63.58	-30.00	-33.58	V	

9. Receiver Spurious Emissions

9.1. Test Limit

The spurious emissions of the receiver shall not exceed the values given in table.

Frequency Range	Maximum Power
30MHz ~ 1GHz	-57dBm
1GHz ~ 12.75GHz	-47dBm

9.2. Test Setup

(A) Radiated Emission Test Set-Up Frequency Bellow 1 GHz.

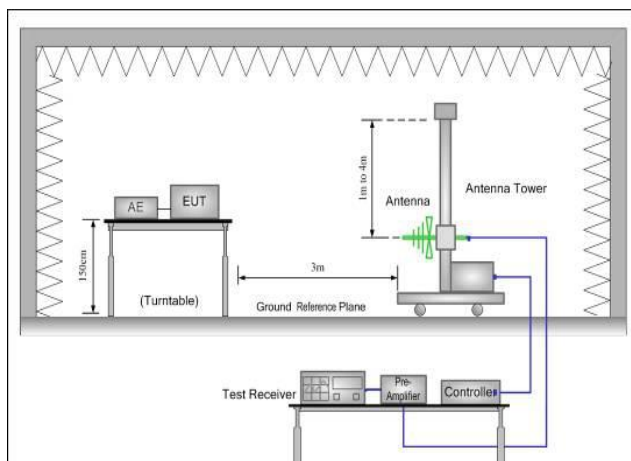

(B) Radiated Emission Test Set-Up Frequency Above 1 GHz.

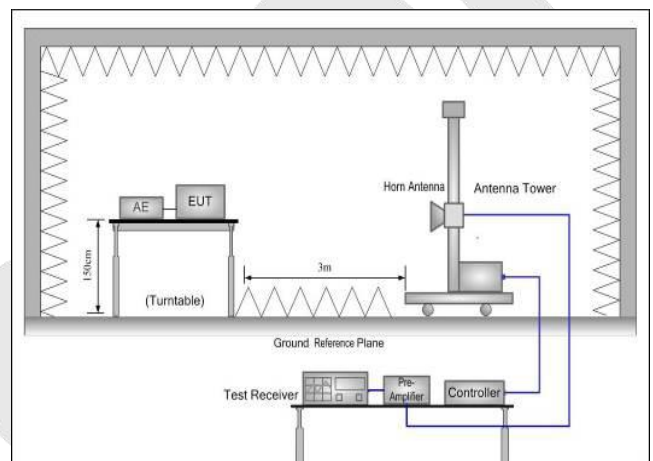

9.3. Test Procedure

Refer as EN 300 328, Refer to chapter 5.4.10.2.2 for radiated measurement.

1. For the actual test configuration, please refer to the related Item in this test report (Photographs of the Test Configuration).
2. Testing was performed when the equipment was in a receive-only mode.
3. The measurements were performed when normal hopping was disabled. In this case measurements were performed when operating at the lowest and the highest hopping frequency.
4. The test setup has been constructed as the normal use condition. Controlling software has been activated to set the EUT on specific status.

9.4. Test Data

Temperature:	25° C	Relative Humidity:	60 %
Pressure:	1012 hPa	Test Voltage:	AC 230V, 50Hz for adapter

The low channel					
Frequency (MHz)	Level(dBm)	Limit (dBm)	Margin(dB)	Polarization	Test Result
74.12	-71.71	-57.00	-14.71	H	PASS
136.42	-68.26	-57.00	-11.26	H	
430.10	-69.44	-57.00	-12.44	H	
791.57	-74.63	-57.00	-17.63	H	
3685.32	-56.16	-47.00	-9.16	H	
6553.80	-60.81	-47.00	-13.81	H	
66.54	-65.54	-57.00	-8.54	V	
146.48	-67.84	-57.00	-10.84	V	
435.78	-68.81	-57.00	-11.81	V	
493.96	-72.58	-57.00	-15.58	V	
3697.27	-57.64	-47.00	-10.64	V	
6068.82	-60.01	-47.00	-13.01	V	

The high channel					
Frequency (MHz)	Level(dBm)	Limit (dBm)	Margin(dB)	Polarization	Test Result
54.80	-70.62	-57.00	-13.62	H	PASS
144.87	-69.97	-57.00	-12.97	H	
350.95	-70.77	-57.00	-13.77	H	
691.86	-68.42	-57.00	-11.42	H	
4011.65	-66.33	-47.00	-19.33	H	
5919.73	-62.08	-47.00	-15.08	H	
51.47	-70.41	-57.00	-13.41	V	
135.75	-66.32	-57.00	-9.32	V	
390.66	-68.06	-57.00	-11.06	V	
630.55	-70.88	-57.00	-13.88	V	
3176.93	-58.80	-47.00	-11.80	V	
6005.43	-66.47	-47.00	-19.47	V	

10. Receiver Blocking

10.1. Test Limit

This requirement applies to all receiver categories.

RECEIVER CATEGORY		
<input checked="" type="checkbox"/> Category 1	Category 2 <input type="checkbox"/>	Category 3 <input type="checkbox"/>
Minimum performance criterion	PER $\leq 10\%$ <input checked="" type="checkbox"/>	
	Alternative performance criteria <input type="checkbox"/>	

Receiver Category 1 Equipment			
Wanted Signal Mean Power From Companion Device (dBm)	Blocking Signal Frequency (MHz)	Blocking Signal Power (dBm)	Type of Blocking Signal
Pmin + 6 dB	2380	-53	CW
	2503.5		
Pmin + 6 dB	2300	-47	CW
	2330		
	2360		
Pmin + 6 dB	2523.5	-47	CW
	2553.5		
	2583.5		
	2613.5		
	2643.5		
	2673.5		

NOTE: Pmin is the minimum level of the wanted signal (in dBm) required to meet the minimum performance criteria.

Receiver Category 2 Equipment			
Wanted Signal Mean Power From Companion Device (dBm)	Blocking Signal Frequency (MHz)	Blocking Signal Power (dBm)	Type of Blocking Signal
Pmin + 6 dB	2380	-57	CW
	2503.5		
Pmin + 6 dB	2300	-47	CW
	2583.5		

NOTE: Pmin is the minimum level of the wanted signal (in dBm) required to meet the minimum performance criteria.

Receiver Category 3 Equipment			
Wanted Signal Mean Power From Companion Device (dBm)	Blocking Signal Frequency (MHz)	Blocking Signal Power (dBm)	Type of Blocking Signal
Pmin + 12 dB	2380 2503.5	-57	CW
Pmin + 12 dB	2300 2583.5	-47	CW

NOTE: Pmin is the minimum level of the wanted signal (in dBm) required to meet the minimum performance criteria.

10.2. Test Setup

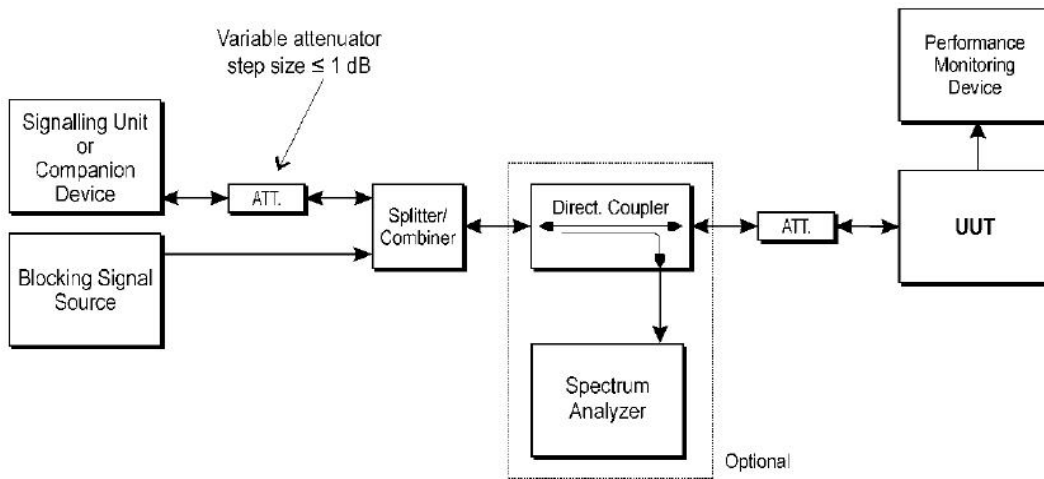

10.3. Test Procedure

Refer to chapter 5.4.11.2.1 of EN 300 328 V2.1.1

10.4. Minimum Performance Declaration

	CH	Pmin (dBm)	PER ($\leq 10\%$)
802.11b	01	-91	Pass
	13	-91	Pass
802.11g	01	-91	Pass
	13	-91	Pass
802.11n(HT20)	01	-91	Pass
	13	-91	Pass
802.11n(HT40)	01	-91	Pass
	13	-91	Pass

Note: Pmin is the minimum level of the wanted signal (in dBm) required to meet the minimum performance criteria.

10.5. Test Data

Temperature:	25° C	Relative Humidity:	60 %
Pressure:	1012 hPa	Test Voltage:	AC 230V, 50Hz for adapter

Wanted Signal Mean Power from Companion Device (dBm/MHz)	Blocking Signal Frequency (MHz)	Blocking Signal Power (dBm)	Type of Blocking Signal	Pass / Fail
-85	2380	-57	CW	PASS
	2503.5			PASS
-85	2300	-47	CW	PASS
	2330			PASS
	2360			PASS
-85	2523.5	-47	CW	PASS
	2553.5			PASS
	2583.5			PASS
	2613.5			PASS
	2643.5			PASS
	2673.5			PASS

APPENDIX I -- TEST SETUP PHOTOGRAPH

