

Wport-W10

Embedded WiFi Module User Manual

V1.0

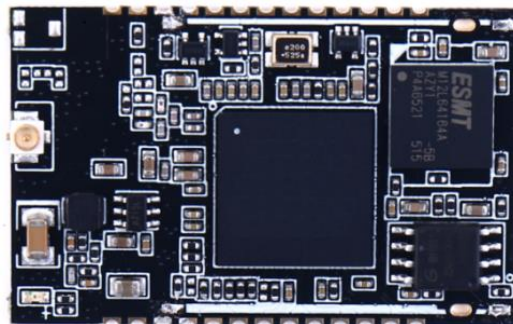

Overview of Characteristic

- ◇ MIPS MCU with 4MB Flash and 8MB SRAM. Run on eCos
- ◇ Support TCP/IP/Telnet /Modbus TCP Protocol
- ◇ Support UART to Ethernet/Wi-Fi Conversion, Serial Speed Upto 230400 bps
- ◇ Support STA/AP/AP+STA Mode
- ◇ Support Router or Bridge Network Working Mode.
- ◇ Support 10/100M Ethernet Auto-Negotiation
- ◇ Support Easy Configuration Through a Web Interface or PC IOTService Tool
- ◇ Support Security Protocol Such As SSL/AES/DES3
- ◇ Support Web OTA Wirelss Upgrade
- ◇ Single **+3.3V** Power Supply
- ◇ Small Size: **25 x 40mm**

TABLE OF CONTENTS

1. PRODUCT OVERVIEW	4
1.1. General Specification	4
1.2. Hardware Introduction	5
1.2.1. Pins Definition	5
1.2.2. Mechanical Size	6
1.2.3. On-board Chip Antenna	7
1.2.4. External Antenna	7
1.2.5. Evaluation Kit	8
1.2.6. Order Information	9
1.3. Hardware Reference Design	9
1.3.1. Hardware Typical Application	9
1.4. Module Usage	10

LIST OF FIGURES

Figure 1.	WPORT-W10 Demo	5
Figure 2.	WPORT-W10 Pins Map.....	5
Figure 3.	WPORT-W10 Mechanical Dimension	6
Figure 4.	WPORT-W10 Chip Antenna Keep Out Region	7
Figure 5.	Suggested Module Placement Region	7
Figure 6.	WPORT-W10 Evaluation Kit	8
Figure 7.	WPORT-W10 Order Information	9
Figure 8.	WPORT-W10 Hardware Typical Application.....	9
Figure 9.	LED&BUTTON Reference.....	10
Figure 10.	Ethernet Reference.....	10

LIST OF TABLES

Table 1	WPORT-W10 Module Technical Specifications	4
Table 2	WPORT-W10 Pins Definition	5
Table 3	WPORT-W10 External Antenna Parameters	8
Table 4	WPORT-W10 Evaluation Kit Interface Description	8

HISTORY

Ed. V1.0 Created on 12-14-2017.

1. PRODUCT OVERVIEW

1.1. General Specification

Table 1 WPORT-W10 Module Technical Specifications

Class	Item	Parameters
Wireless Parameters	Wireless standard	802.11 b/g/n
	Frequency range	2.412GHz-2.484GHz
	Transmit Power	802.11b: +20 dBm (Max.)
		802.11g: +18 dBm (Max.)
		802.11n: +15 dBm (Max.)
	Receiver Sensitivity	802.11b: -89 dBm
		802.11g: -81dBm
		802.11n: -71dBm
Antenna Option	External:I-PEX Connector	
	Internal:On-board chip antenna	
Hardware Parameters	Data Interface	UART: 1200bps - 230400bps
		GPIO
		Ethernet: 100Mbps
	Operating Voltage	3.3V (+/-5%)
	Operating Current	170mA~300mA
	Operating Temperature	-40°C - 85°C
	Storage Temperature	-45°C - 125°C
Dimensions and Size	25×40×3mm SMT	
Software Parameters	Network Type	STA /AP/AP+STA mode
	Security Mechanisms	WEP/WPA-PSK/WPA2-PSK/WAPI
	Encryption	WEP64/WEP128/TKIP/AES
	Work Mode	Transparent Transmission and
	Serial command	AT+instruction set
	Network Protocol	TCP/UDP/ARP/ICMP/DHCP/DNS/HTTP
	Max. TCP Connection	32
	User Configuration	Web Server + AT command config.
User Application SW	Support customized application SW Provide SDK package Provide smart link tools	

1.2. Hardware Introduction

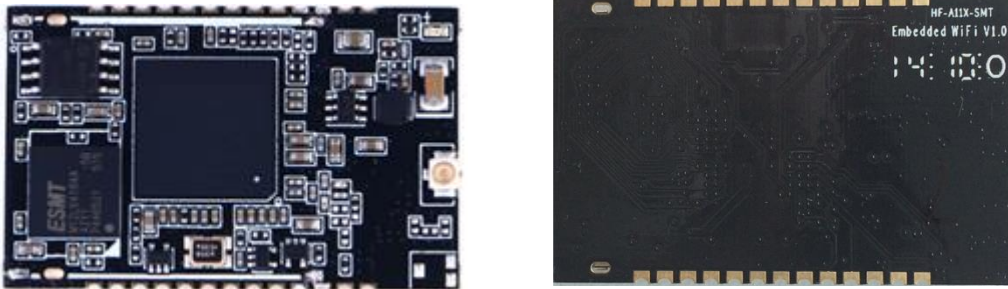

Figure 1. WPORT-W10 Demo

1.2.1. Pins Definition

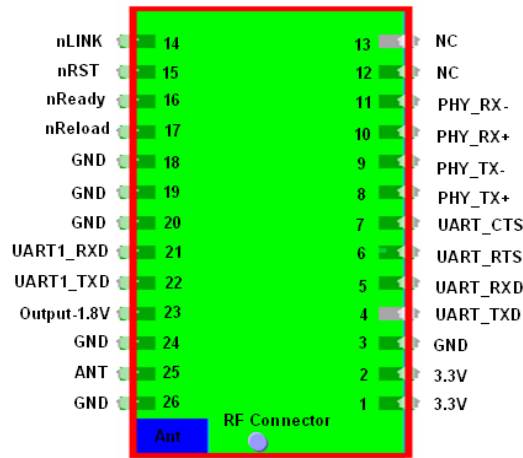

Figure 2. WPORT-W10 Pins Map

Table 2 WPORT-W10 Pins Definition

Pin	Description	Name	Direction	Note
3,18,19,20,24,26	Ground	GND	Power	
1,2	VCC	3.3V	Power	3.3V @ 350mA
4	UART Data Transmit	UART_TXD	O	If not use UART function, this 4 pins can be configured as GPIO pins, and can change GPIO pin status through AT command
5	UART Data Receive	UART_RXD	I	
6	UART sends request of data transmission	UART_RTS	O	
7	UART receives data transmission permission	UART_CTS	I	
8	Ethernet Interface	PHY_TX+	O	+1.8V Ethernet Data Interface.Support
9	Ethernet Interface	PHY_TX-	O	

10	Ethernet Interface	PHY_RX+	I	transformer and direct connection (AC couple) mode.
11	Ethernet Interface	PHY_RX-	I	
14	Network status Indication	nLink	O	“1”- Network connection OK “0”- No network connection
15	Module reset signal	nRST	I	“Low (0)” effective reset input. The reset duration should be kept more than 300ms
16	485_IO_EN	nReady	O	RS485 control pin for half-duplex function
17	Restore configuration	nReload	I	Module will Restore factory default configuration after set this pin “0” more than 3s, then set “1”. This pin must 4.7K pull-up outside the module.
21	Protect	UART1_RXD	I	Parameter protect function. Should add pull-up resistor for protect enable.
22	Active	UART1_TXD	O	Data send and receive indicator.
23	Output 1.8V	1.8V	O	1.8V@300mA , for Ethernet
25	2.4GHz Antenna	ANT	O	50 Ohm resistance control
12,13	Reserved	NC	NC	

1.2.2. Mechanical Size

WPORT-W10 modules physical size as follows:

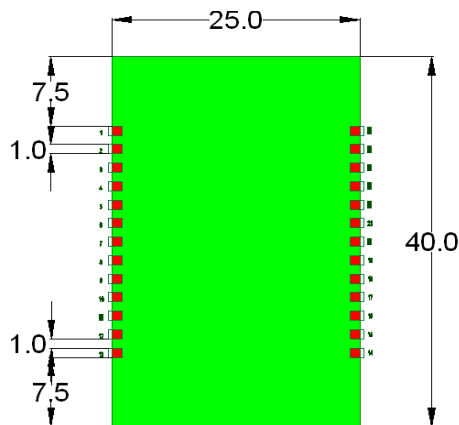

Figure 3. WPORT-W10 Mechanical Dimension

1.2.3. On-board Chip Antenna

WPORT-W10 module supports internal on-board chip antenna option. When customers select internal antenna, you shall comply with following antenna design rules and module location suggestions:

- For customer PCB, RED color region (7x7mm) can't put componet or paste GND net;
- Antenna must away from metal or high components at least 10mm;
- Antenna can't be shieldedby any meal enclosure; All covered, include plastic, shall be away from antenna at least 10mm;

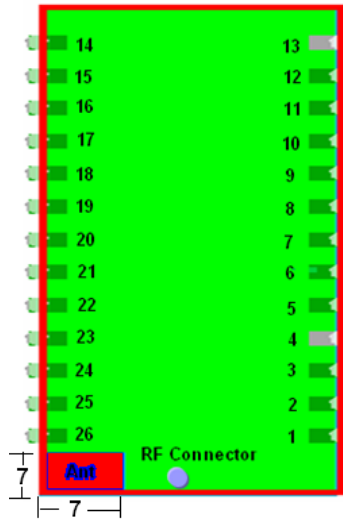

Figure 4. WPORT-W10 Chip Antenna Keep Out Region

High-Flying suggests WPORT-W10 module better located in following region at customer board, which is to reduce the effect to antenna and wireless signal. And it is better to consult High-Flying technical people when you structure your module placement and PCB layout.

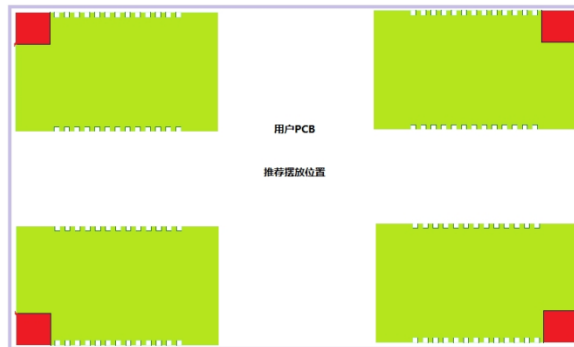

Figure 5. Suggested Module Placement Region

1.2.4. External Antenna

WPORT-W10 modules support internal antenna and external antenna option for user dedicated application. If user select external antenna, WPORT-W10 modules must be connected to the 2.4G antenna according to IEEE 802.11b/g/n standards.

The antenna parameters required as follows:

Table 3 WPORT-W10 External Antenna Parameters

Item	Parameters
Frequency range	2.4~2.5GHz
Impedance	50 Ohm
VSWR	2 (Max)
Return Loss	-10dB (Max)
Connector Type	I-PEX or populate directly

1.2.5. Evaluation Kit

High-Flying provides the evaluation kit to promote user to be familiar with the product and develop the detailed application. The evaluation kit is shown as below, user can connect to the WPORT-W10 module with the RS-232 UART port, 100M Eth port or Wireless port to configure the parameter, manage the module or do some functional tests.

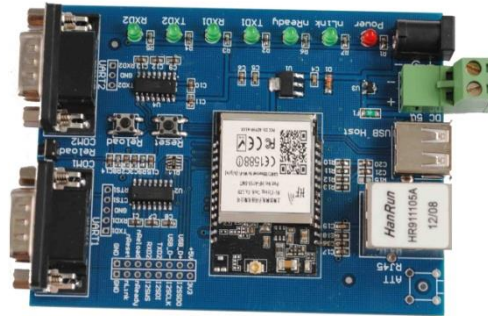

Figure 6. WPORT-W10 Evaluation Kit

The external interface description for evaluation kit is as follows:

Table 4 WPORT-W10 Evaluation Kit Interface Description

Function	Name	Description
External Interface	DC-Jack	5V@1A Power input: DC-Jack
	DC 5V	5V@1A Power input: 2-Pin
	COM1 UART	DB9, UART, Connect PC serial port
	COM2 UART1	DB9, UART1, Connect PC serial port
	RJ-45	100M Ethernet Interface
	USB Host	Served USB (Type A)
	DIP-16	Extended 16-pin functional interface
	ATT	2.4GHz , SMA external antenna interface
LED	Power (Red)	3.3V Power Indicator
	nLink	nLink/GPIO-Pin 14 Indicator
	nReady	nReady/GPIO-Pin 16 Indicator
	TXD1	UART0/GPIO-Pin 4 Indicator
	RXD1	UART0/GPIO-Pin 5 Indicator
	TXD2	UART1/GPIO-Pin 22 Indicator
	RXD2	UART1/GPIO-Pin 21 Indicator

Button	Reset	Used to reset the module.
	Reload	Module restore to factory default configuration.

1.2.6. Order Information

Base on customer detailed requirement, WPORT-W10 series modules provide different variants and physical type for detailed application.

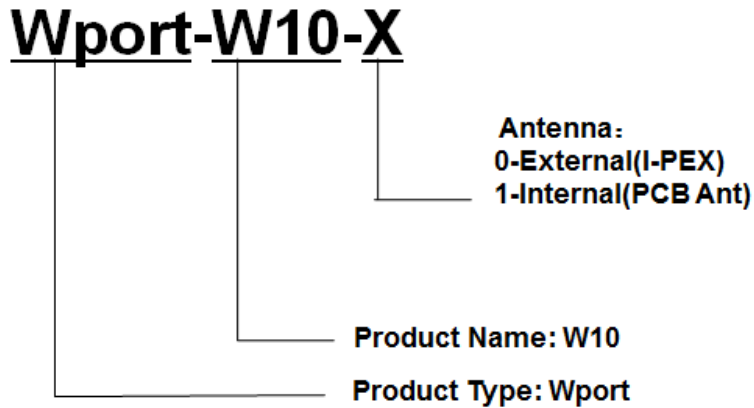

Figure 7. WPORT-W10 Order Information

1.3. Hardware Reference Design

1.3.1. Hardware Typical Application

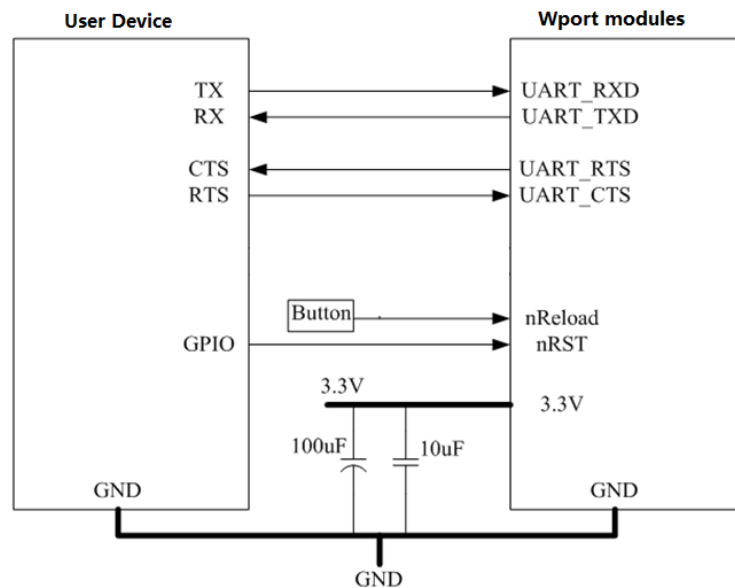

Figure 8. WPORT-W10 Hardware Typical Application

Notes:

nRST- Module hardware reset signal. Input. Logics "0" effective. There is 100K Ohm pull-up resistor internal. When module power up or some issue happened, MCU need assert nRST signal "0" at least 300ms, then set "1" to keep module fully reset.

nLink- Module WIFI connection indication. Output.

There is 4.7K Ohm pull-up resistor inside. When module connect to AP (STA mode) or some WiFi STA connect to module (AP mode), the module will output “0”. This signal is used to judge if module already at WiFi connection status.

nReload- Module restore to factory default configuration.Input. Logics “0” effective.

User can assert nReload signal “0” more than 3’s through button or MCU pin, then release, module will restore to factory default configuration and re-start boot up process. **User needs add 4.7K~10K Ohm pull-up resistor external the module.**

UART_TXD/RXD- UART port data transmit and receive signal.

There is 1K Ohm pull-down resistor inside. User can not add pull-up resistor at these pins.

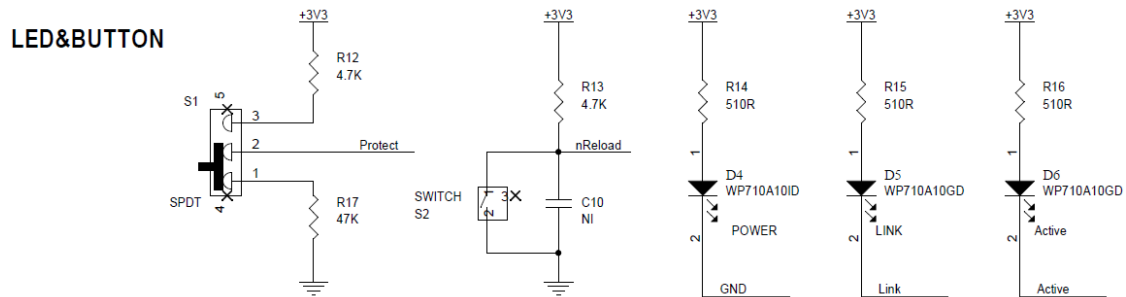

Figure 9. LED&BUTTON Reference

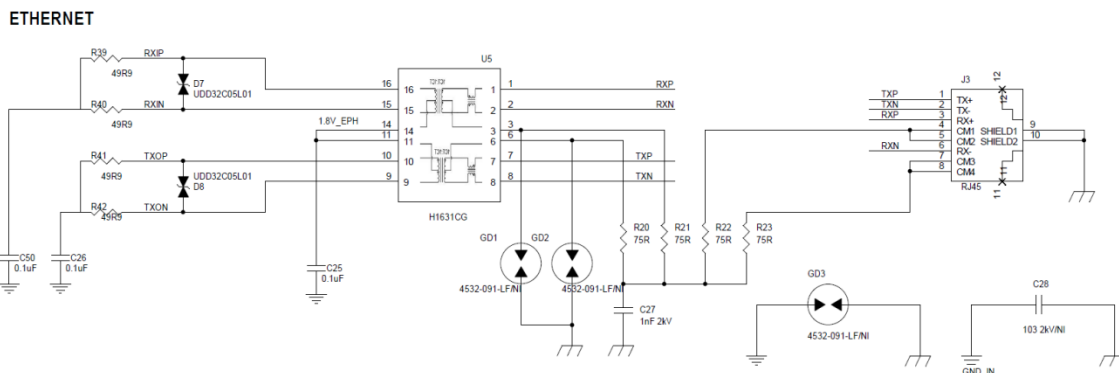

Figure 10. Ethernet Reference

1.4. Module Usage

This module is used in HF2211, see HF2211 manual for detailed usage.