

HF-BL300

Bluetooth Low Energy (BLE 5.0) Module User Manual

V 1.1



Overview of Characteristic

- ✧ Support BLE5.0 Standard. Max 2Mbps Data Rate
- ✧ Support Wireless OTA Upgrade
- ✧ UART Transparent Transmit Module
- ✧ Support SIG Mesh
- ✧ Supper Low Sleep Mode, 3.5uA. Excellence Power Save Scheme Suitable for Battery-Powered Applications
- ✧ Support Internal Antenna
- ✧ Single 1.8V~3.6V Power Supply
- ✧ Size: 26mm x 14.5mm

Table of Contents

LIST OF FIGURES	4
LIST OF TABLES	4
1. PRODUCT OVERVIEW	6
1.1. General Description	6
1.2. Key Application	6
1.3. Device Parameter	7
1.4. Order information.....	7
2. HARDWARE INTRODUCTION	9
2.1. Pin Definition	9
2.2. Electrical Specification.....	10
2.3. Mechanical size	11
2.4. Antenna Layout	12
3. UART TRANSPARENT TRANSMIT MODE	14
3.1. Transparent Transmit Mode.....	14
3.2. Transparent Transmit Mode Pin Description	15
3.3. Enable Module Deep Sleep	16
3.4. Restore Factory Setting via Hardware Method	16
3.5. Factory Default Parameter	16
3.5.1. Device Name	16
3.5.2. Broadcast Parameter	17
3.5.3. Transmit Power	17
3.5.4. Connect Parameter.....	17
3.5.5. Baud rate	17
3.5.6. Send Latency Parameter	17
4. UART AT COMMAND DEFINITION	18
4.1. Module Operation Mode Configure	18
4.2. AT:Command Overview	18
4.2.1. Command Format.....	19
4.2.2. Command List.....	20
4.3. AT Command.....	22
4.3.1. AT:HELP Help command.....	22
4.3.2. AT:REN- Set Module NAME	22
4.3.3. AT:REN? Query module Name	22
4.3.4. AT:CIT- Set Connect Parameter.....	23
4.3.5. AT:CIT? Query Connect Parameter	23
4.3.6. AT:BPS- Set Baud rate.....	24
4.3.7. AT:BPS? Query Baud rate.....	25
4.3.8. AT:MAC? Get MAC Address	25
4.3.9. AT:VER? Query Software Version	25

4.3.10.	AT:TPL- Set Transmit Power	26
4.3.11.	AT:TPL? Query Transmit Power	26
4.3.12.	AT:ADP- Set Broadcast Parameter.....	27
4.3.13.	AT:ADP? Query Broadcast Parameter	28
4.3.14.	AT:ADV- Set User-define Broadcast Data	28
4.3.15.	AT:ADV? Query User-define Broadcast Data	28
4.3.16.	AT:ADVAL- Set Auto-broadcast Switch	29
4.3.17.	AT:ADVAL? Query Auto-broadcast Switch.....	29
4.3.18.	AT:ADVSTART Start Broadcast.....	30
4.3.19.	AT:ADVSTOP Stop Broadcast.....	30
4.3.20.	AT:CNN-D Disconnect	31
4.3.21.	AT:PID- Set Device Verify Code	31
4.3.22.	AT:PID? Query Device Verify Code.....	32
4.3.23.	AT:SAVE Save Parameter	32
4.3.24.	AT:RST Module Restore	33
4.3.25.	AT:RELD Restore Factory Setting via At Command	33
4.3.26.	AT:UIDS Change Service UUID.....	33
4.3.27.	AT:UIDR Change APP Receive Channel UUID.....	34
4.3.28.	AT:UIDW Change APP Send Channel UUID	34
5.	APP COMMAND.....	35
5.1.	Channel and Data Description.....	35
5.2.	Data Format	35
5.3.	Command Content.....	35
5.3.1.	Command Type:0x0E	35
5.3.2.	Command Type:0x0F	36
6.	BASIC COMMUNICATION MECHANISIM	38
6.1.	Application Service Data Channel (user-define application service UUID:0x2B00) ...	38
6.1.1.	Module->APP, UART Data Channel 【feature UUID:0x2B10】	38
6.1.2.	APP->Module,UART Data Channel 【feature UUID:0x2B11】	38
6.1.3.	APP->Module,OTA Mode Switch 【Feature UUID:0x2B12】	39
6.1.4.	APP->Module,APP Command Channel 【Feature UUID:0x2B13】	39
6.2.	Battery Service Data Channel.....	39
6.2.1.	APP->Module,Battery Data Channel 【Feature UUID:0x2A19】	39
6.3.	OTA Service Data Channel.....	40
6.3.1.	APP->Module,OTA Data Channel	40
7.	PACKAGE INFORMATION.....	41
7.1.	Reflow Soldering Profile	41
7.2.	Handling Instruction	41
APPENDIX A: UART TRANSPARENT TRANSMIT TYPICAL APPLICATION.....		42
APPENDIX D: CONTACT INFORMATION		44

LIST OF FIGURES

Figure 1.	HF-BL300 SOC Block Diagram.....	6
Figure 2.	HF-BL300 order information.....	8
Figure 3.	HF-BL300 Pin Definition.....	9
Figure 4.	HF-BL300 Mechanical size.....	12
Figure 5.	HF-BL300 Module Reference Placement.....	12
Figure 6.	HF-BL300 Module Bulb Reference Placement.....	13
Figure 7.	Basic HF-BL300 wireless network structure.....	14
Figure 8.	Module UART Receive Enable Signal Map.....	16
Figure 9.	HF-BL300 Default UART Parameter.....	18
Figure 10.	"AT:HELP" list All command.....	19
Figure 11.	Reflow Soldering Profile.....	41
Figure 12.	UART Transparent Transmit Typical Application.....	42

LIST OF TABLES

Table1.	HF-BL300 Module Technique Specification.....	7
Table2.	HF-BL300 Pin Function Definition.....	9
Table3.	Limited Specification.....	10
Table4.	Electrical Specification.....	11
Table5.	RF Specification.....	11
Table6.	Communication Data Rate.....	15
Table7.	Error Code list.....	20
Table8.	AT Command List.....	20
Table9.	Command Data from APP to Module.....	35
Table10.	Feedback Data from Module to APP.....	35
Table11.	Command Type 0x0F command list.....	36
Table12.	Command Type 0x0F Feedback List.....	36
Table13.	Description of User-define Service of All Channel.....	38
Table14.	0x2B10 feature UART Module->APP Channel Description.....	38
Table15.	0x2B11 Feature UART APP->Module Channel Description.....	38
Table16.	0x2B12 Feature OTA Mode Switch Channel Description.....	39
Table17.	0x2B13 Feature APP Command Channel Description.....	39
Table18.	Description of Battery Service of All Channel.....	39
Table19.	0x2A19 Feature Battery Power Channel Feature Description.....	39
Table20.	Description of OTA Service of All Channel.....	40
Table21.	Feature OTA Data Channel Feature Description.....	40
Table22.	Reflow Soldering Specification.....	41

HISTORY

V 1.0 02-13-2019. First Version

V 1.1 04-11-2019. Update MANUFACTURE pin function and AT command

1. PRODUCT OVERVIEW

1.1. General Description

HF-BL300 Bluetooth Low Energy module is a high performance IOT module designed by High Flying. It provide a solution for connecting things to Bluetooth wireless network and data transmitting via UART interface. With the feature of low power, small size, high anti-interference performance, the module integrates PCB antenna and use open stamp type interface which enable customer have more flexibility on software and product structure , and solve the RF hardware design and debug issue.

The HF-BL300 SOC chip block diagram is as following.

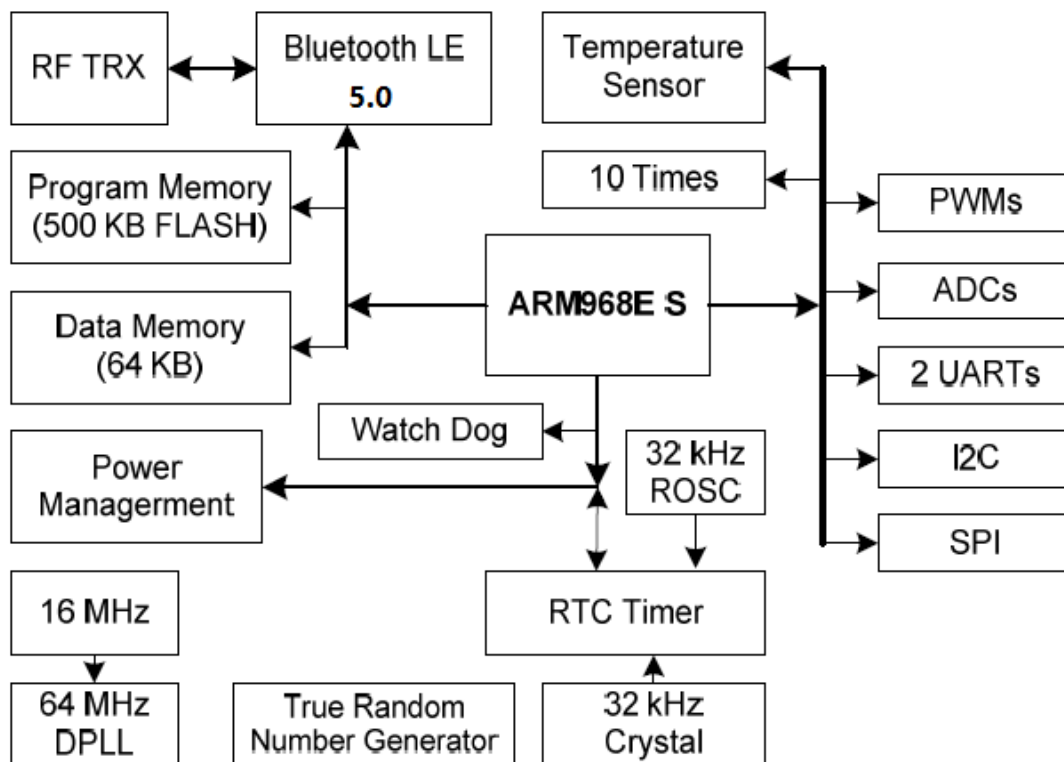

Figure 1. HF-BL300 SOC Block Diagram

1.2. Key Application

- Smart LED lighting
- Smart toy
- Electronic Scale
- Smart Cup
- Smart Home Appliance
- OBD
- IOT, Smart Home Automation

- Sports, fitness, customer electronics products
- Smart instrument, data acquisition sensor
- PC, Tablet peripheral interface

1.3. Device Parameter

Table1. HF-BL300 Module Technique Specification

Class	Item	Condition	Parameter	
Wireless parameter	Certificate		TBD	
	Wireless standard		802.15.1	
	Frequency range		2.402GHz-2.480GHz	
	Data rate		2Mbps@2.4GHz	
	Tx power		Max=+10 dBm,	
	Rx sensitivity		-93 dBm	
Hardware parameter	Data interface		UART SPI I2C PWM ADC	
	Operating voltage		1.8~3.6V	
	Power consumption	Dormant		2uA
		Sleep		3~11uA
		DIG Active		5mA
		RF Active		20mA
	Average power consumption	20ms broadcast		3.2mA
		0.5ms broadcast		130uA
		4s broadcast		1.3uA
		30ms connection		19uA
		100ms connection		290uA
		4s connection		10uA
	Distance	Outdoor		30 meters
		Indoor		15 meters
	Work temperature			-40℃- 125℃
Storage temperature			-45℃- 125℃	
Size			26mm x 14.5mm	

1.4. Order information

As customer demand, HF-BL300 can provide variant physical version, detail part number as below:

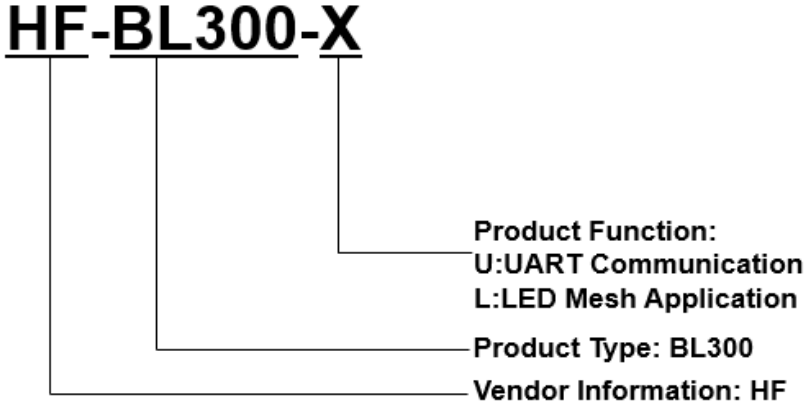

Figure 2. HF-BL300 order information

2. HARDWARE INTRODUCTION

2.1. Pin Definition

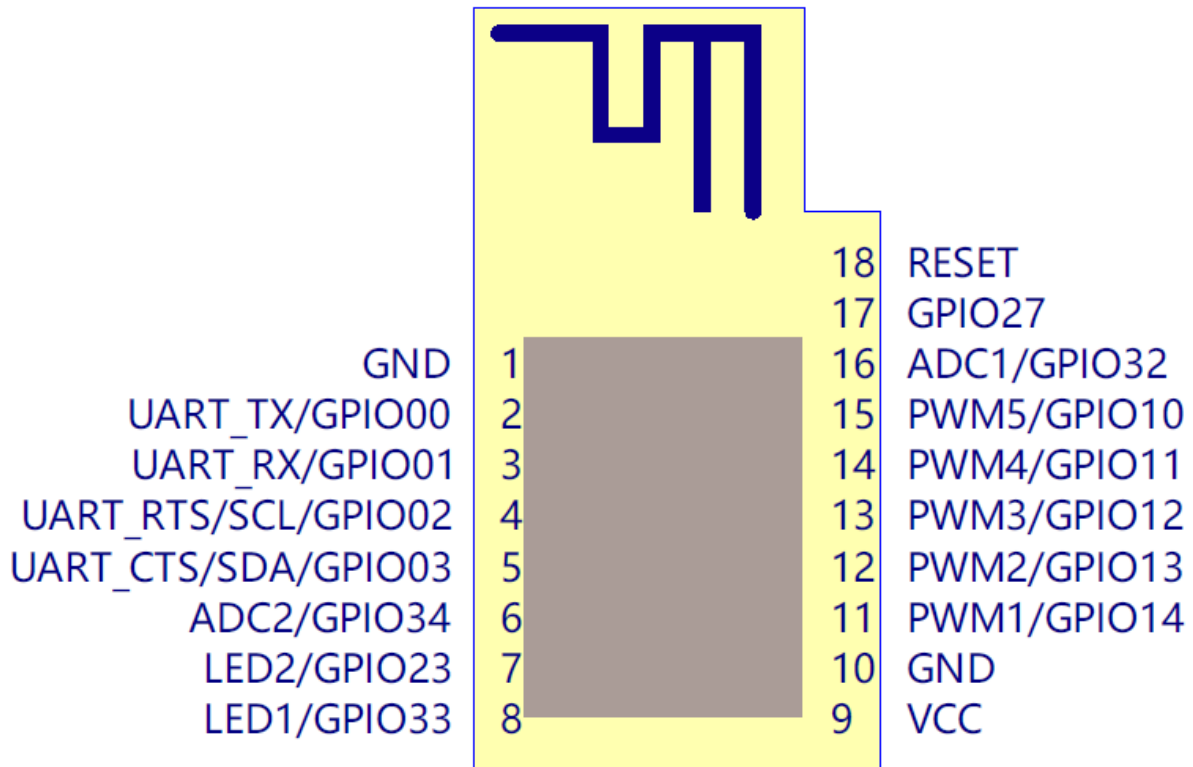

Figure 3. HF-BL300 Pin Definition

Table2. HF-BL300 Pin Function Definition

Pin	Description	Net Name	Signal Type	Comments
1,10	Ground	GND	Power	
2	UART_TX	UART_TX	O	3.3V TTL UART0 Communication Output GPIO00
3	UART_RX	UART_RX	I	3.3V TTL UART0 Communication Input GPIO01
4	UART_RTS	UART_RTS	I/O	Can be used as SCL GPIO02, leave it open if not use
5	UART_CTS	UART_CTS	I/O	Can be used as SDA GPIO03, leave it open if not use
6	BCTS	ADC2	I/O	The default output low, high data output is sent, used to wake up the MCU, the data is sent after the output low

Pin	Description	Net Name	Signal Type	Comments
				GPIO34, leave it open if not use
7	MANUFACTURE	LED2	I/O	Pull Low for more than 5 seconds to restore the factory settings, GPIO23, leave it open if not use(internal has low pull-up)
8	WAKEUP	LED1	I/O	Pull low to wake up module, if does not need power save, direct connect this pin to GND GPIO33
9	VCC	VCC	Power	DC Power input,1.8V~3.6V, recommend 3.3V
11	PWM1	PWM1	O	Cold LED, high effective GPIO014, leave it open if not use
12	PWM2	PWM2	O	Warm LED, high effective GPIO013, leave it open if not use
13	PWM3	PWM3	O	RGB Red LED, high effective GPIO012, leave it open if not use
14	PWM4	PWM4	O	RGB Green LED, high effective GPIO011, leave it open if not use
15	PWM5	PWM5	O	RGB Blue LED, high effective GPIO010, leave it open if not use
16	ADC1	ADC1	I/O	GPIO032, leave it open if not use
17	GPIO27	GPIO27	I/O	GPIO027, leave it open if not use
18	RESET	RESET	I/O	"Low" effective reset input. Keep more than 10ms, leave it open if not use

<Notes>

I — Input; O — Output

PU—Internal Resistor Pull Up; I/O: Digital I/O; Power—Power Supply

PWM function:

PWM1~PWM5 is for LED Mesh application, it direct output PWM, control the LED duty cycle, add transistor or MOSFET to amplify.

2.2. Electrical Specification

Table3. Limited Specification

Parameter	Description	Min Value	Typ. Value	Max value	Unit
VPIN	Pin voltage limit	-0.1	-	VCC	V
T_VRISE	Power up time	5	-	100	mS
ESD_HBM				4000	V
ESD_MM				100	V
ESD_CDM				500	V
Storage temperature range		-50		150	°C

Table4. Electrical Specification

Parameter	Condition	Min Value	Typ. Value	Max Value	Unit
Work voltage		1.8	3.3	3.6	V
Work temperature		-40		125	°C
I_DORM	Dormant status		2		uA
I_SLEEP	Sleep status		3		uA
I_TX0DBM	TX Mode 0dBm		23		mA
I_TX10DBM	TX Mode, 10dBm		45		mA
I_TXN20DBM	TX Mode -20dBm		15		mA
I_RX	RX default		20		mA
	System clock =24Mhz		7.1		mA
	System clock =12Mhz		4		mA
	System clock =6Mhz		2.5		mA
	System clock =3Mhz		1.7		mA
Sleep mode	Operating 3Mhz		1.1		mA
Deep sleep mode	ECO Stop,WCO work		1.3		uA
Stop mode	ECO Stop,WCO work		60		nA

Table5. RF Specification

Parameter	Min value	Typ. Value	Max value	Unit
Receiving sensitivity		-96		dBm
Operating frequency range	2400		2483	MHz
Frequency deviation	225	250	275	KHz
Output Power	-20		4	dBm
Frequency tolerance		±50		Ppm
Signal strength accuracy		±5		dBm
Signal accuracy		1		dBm

2.3. Mechanical size

HF-BL300 physical size (unit: mm) as below:

HF-BL300 Pads: Size 26mm X 14.5mm, pad pitch 1.27mm

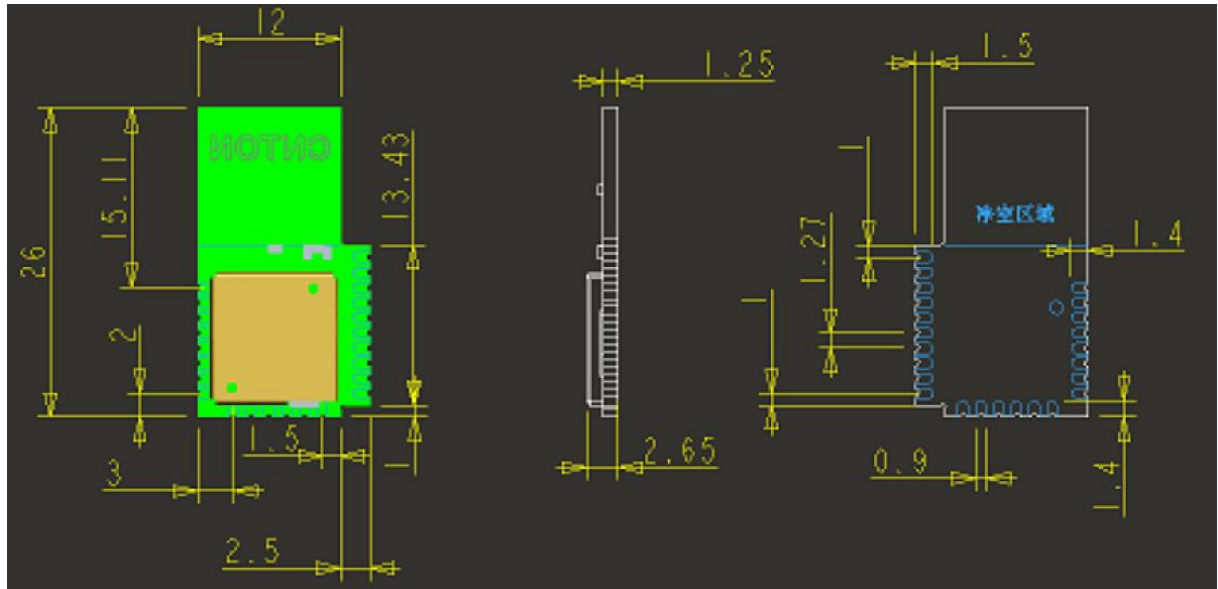

Figure 4. HF-BL300 Mechanical size

2.4. Antenna Layout

HF-BL300 supports internal antenna. Customers need to obey following antenna design rules and module location suggestions:

- For user PCB, place module on the edge area of the PCB as possible, or suspend the antenna area.
- Module antenna correspondent area can't put components or paste GND, the surrounding components or GND should be as far as possible from antenna place.
- Antenna must be away from high components at least 10mm.
- Antenna can't be shielded by any metal enclosure.

High Flying suggests to locate HF-BL300 as following picture to reduce the influence to antenna and wireless signal as much as possible, or contact High Flying technique people for support

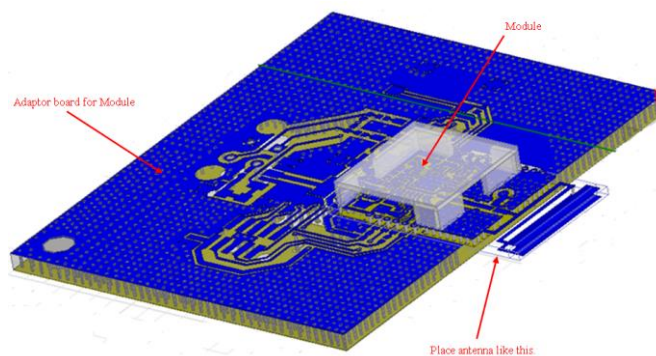

Figure 5. HF-BL300 Module Reference Placement

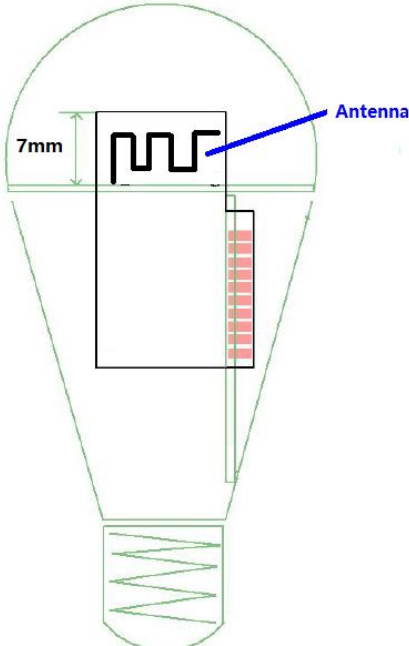

Figure 6. HF-BL300 Module Bulb Reference Placement

3. UART TRANSPARENT TRANSMIT MODE

3.1. Transparent Transmit Mode

Transparent Transmit means the bi-direction communication between device and mobile terminal. Device can set HF-BL300 parameters (refer to “AT Command” chapter). Target different baud rate and BLE connect interval or different packet sending interval, module would have different data handling capacity. The default baud rate of HF-BL300 is 115200bps, it is recommended to set baud rate at 115200bps when transmitting big data or in highly real-time application. Baud rate support save after power off.

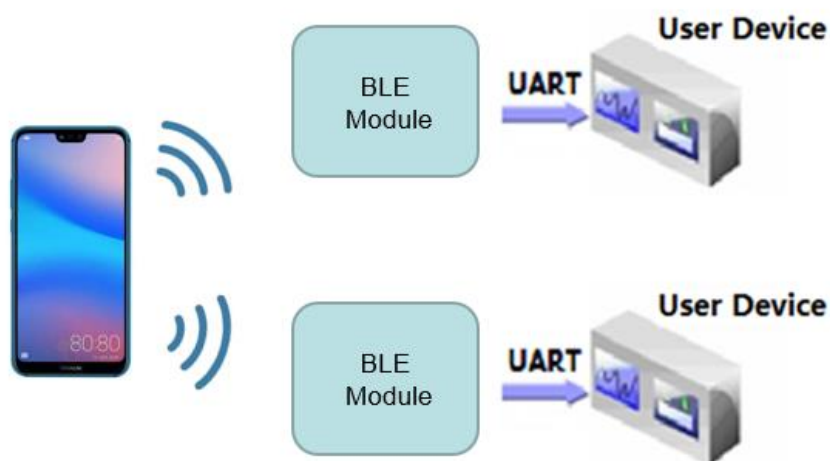

Figure 7. Basic HF-BL300 wireless network structure

Module can receive almost 800 bytes data from serial interface one time. Module will automatically send sub-packet according to data size, each packet limit is 200 bytes. The data packet sending from mobile device to module must be separated to sub-packet(1~200 byte each). After receiving the sub-packets, module will send to MCU in proper order.

Serial hardware protocol: 115200 bps, 8,non-parity, 1 stop bit

After receiving data from MCU serial port, module will judge if it is AT command. If it is, module will execute the command. If not, module will transmit the data to APP under BLE connection and notify mode enabled status.

After module receives APP data, it will output the data to MCU via serial interface.

If module system status changed, module will send status notification character to MCU, such as disconnect, connect, broadcast.

Bluetooth protocol require that the minimum connect interval is 7.5ms. Default connect interval is 20ms (comply with IOS regulation), if it is needed to save power and apply low speed transmit mode.

User can adjust connect interval through AT command (the maximum connect interval is 2000ms, comply with IOS regulation)

The calculation of transmit speed: the data packet of each connection interval from APP to module is 1 packet, max 4 packet can be transmitted from module to APP in each interval (the packet is related to module CPU capacity). There is maximum 200 bytes in each packet, if connect interval is T (unit: ms), then max transmit speed V (unit is byte/s) is:

$$V_{\text{module}} = 200 \times 4 \times 1000 / T \quad (V \text{ only related } T)$$

$$V_{\text{app}} = 200 \times 1000 / T \quad (V \text{ only related } T)$$

Vapp: if module connect interval is 20ms, then each interval can transmit max 200 bytes, so theoretically the max speed is 200x50 =10k byte/s. Test shows the transmit from APP to module is stable and reliable.

Vmodule: if module connect interval is 20ms, then each interval can transmit maximum 800 bytes, so theoretically the maximum speed is 800x 50=40k byte/s.

Baud rate also take effect on the communication rate, 115200 speed is about 10KB.

Below is the example of 20ms connect interval communication mode, user can self-configure. The lower the Speed, the lower the packet lost ratio.

Table6. Communication Data Rate

Connect Interval T (ms)	Max Data Rate V V=800*1000/T	UART packet length L	UART packet interval TS(ms) L<800, TS>=T 800<L<160, TS>=2*T 800<L<1000, TS>=3*T	Actual Data Rate V0 V0=L*1000/TS
20	40K	80	TS>T, TS=20ms	80*1000/20=4KB
20	40K	400	TS=20ms	400*1000/20=20KB
20	40K	900	TS=40ms	900*1000/40=36KB

Note:

In IOS, the function is used to call Characteristic is: BCharacteristicWriteWithResponse parameter: “write with response” mode would lower transmit efficiency to ensure the accuracy of each packet. Using “CBCharacteristicWriteWithoutResponse”; “write without response” mode would promote transmit efficiency, but the accuracy of packet need to be verified by APP up level.

3.2. Transparent Transmit Mode Pin Description

All pins of Transparent Transmit :UART_TX, UART_RX, WAKEUP, BCTS, MANUFACTURE

Min. pins of Transparent Transmit:UART_TX, UART_RX, WAKEUP

Pin	Description	Net Name	Signal Type	Comments
2	UART_TX	UART_TX	O	3.3V TTL UART0 Communication Output
3	UART_RX	UART_RX	I	3.3V TTL UART0 Communication Input
6	BCTS	ADC2	I/O	The default output low, high data output is sent, used to wake up the MCU, the data is sent after the output low
7	MANUFACTURE	LED2	I/O	Pull low for more than 5 seconds to restore the factory settings,
8	WAKEUP	LED1	I/O	Pull low to wake up module, if does not need power save, direct connect this pin to GND

WEAKEUP: inside high impedance, pin must be connected. Pull up to stop UART receive function.

UART is unable to receive data (UART able to send data). Pull down to enable UART to receive data.

XRES: Pull up inside, can be no connection

BCTS: In normal time, output low level; BCTS output high level before sending data from module, after sending, BCTS output low level.

3.3. Enable Module Deep Sleep

Function: enable module CPU subsystem deep sleep, (BLE subsystem isolate operation), non deep sleep mode module can receive data via UART, under deep sleep module UART function is disabled

Effective time: immediately

Command:

PIN32->WAKEUP: high level ->CPU subsystem enter deep sleep , module UART don't receive data

PIN32->WAKEUP: low level-> CPU is not allowed to enter deep sleep, module UART able to 不允 receive data

Need to pay attention to actual level and data sending sequence, sending data must wait 50 us after set high level to low level, after sending finished, and must waiting another 50 us to set low level to high level

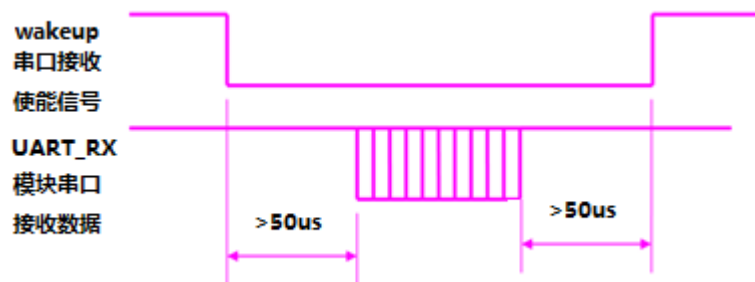

Figure 8. Module UART Receive Enable Signal Map

3.4. Restore Factory Setting via Hardware Method

Function: All changeable parameter restore to factory setting, include baud rate, device name, transmit power, user-define broadcast data, UART data latency data, verify code ,broadcast parameter, connect parameter

Effective time: Immediately

Command:

PIN29->MANUFACTURE:

Feedback:

"AT:RELOAD\r\n" means accept command to restore factory setting

3.5. Factory Default Parameter

3.5.1. Device Name

Device NAME: "HF-BL300"

3.5.2. Broadcast Parameter

Broadcast Min. interval: "0800", means 500ms

Broadcast Max. interval: "0800", means 500ms

Broadcast type: "0", means public

Broadcast channel : "7", means apply channel index 37 38 39

3.5.3. Transmit Power

Broadcast transmit power : "8", means 0dbm

Connect transmit power : "8" means 0dbm

3.5.4. Connect Parameter

Min interval : "0016", means 20ms

Max interval : "0032", means 40ms

Slave Latency : "0", means 0

Connect timeout : "0200", means 2000ms

3.5.5. Baud rate

Baud rate: "115200"

3.5.6. Send Latency Parameter

Serial sending Latency: "01", means 1ms

4. UART AT COMMAND DEFINITION

4.1. Module Operation Mode Configure

After HF-BL300 power on, module enter transparent transmit mode, default UART configuration parameter is as below:

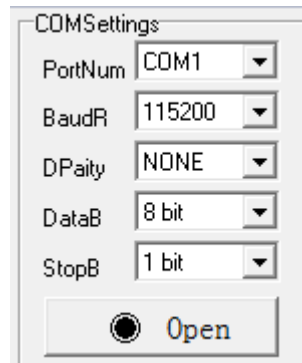

Figure 9. HF-BL300 Default UART Parameter

User can configure the module via AT command through UART or use Evaluation Kit to test.

<Note>: AT command debug tool recommend use “friend serial debug assistant” and SecureCRT tool ,which can be download from company website.

4.2. AT:Command Overview

AT: command can be inputted via serial debug tool or compile as below photo shows, AT:HELP is a help command, list all commands and description.

Remark: the end of each command need add return or line feed character.

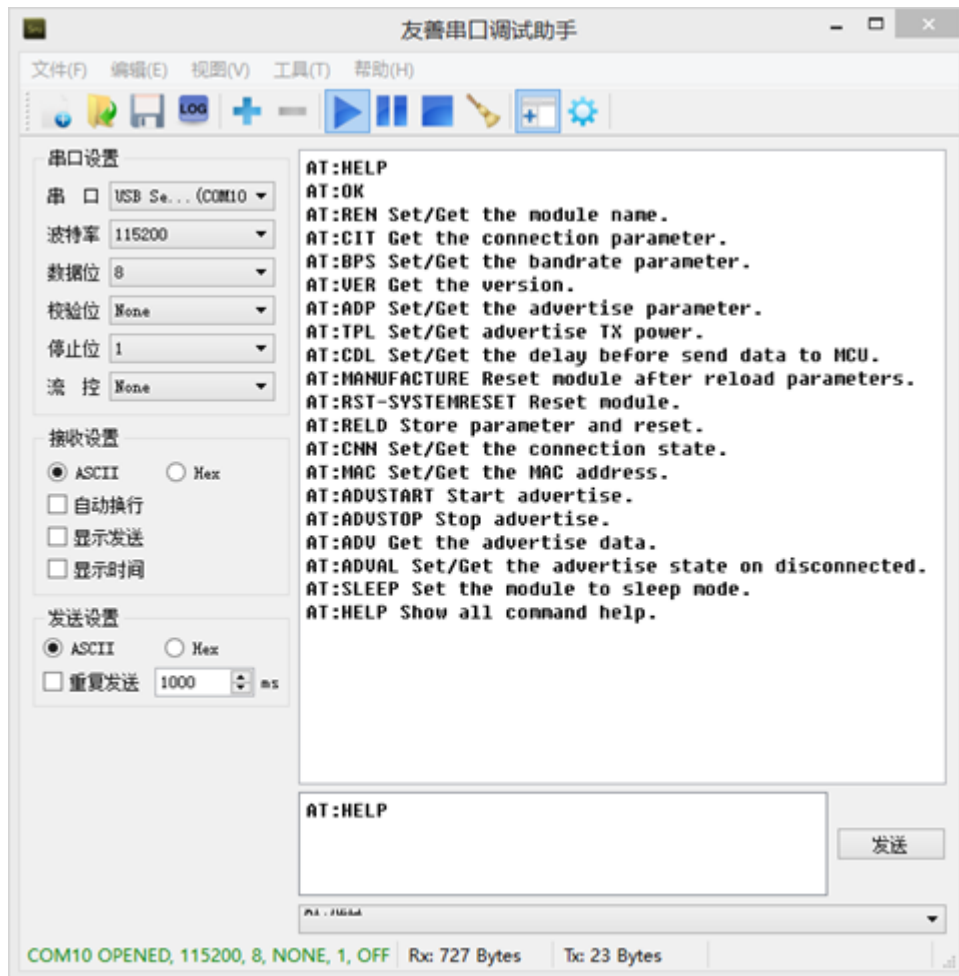

Figure 10. "AT:HELP" list All command

4.2.1. Command Format

AT: command based on ASCII code, format as below:

- Format description
 - <>: mean the part must include
 - []: mean optional part
- Command message

AT:<CMD>[op][para-1,para-2,para-3,para-4...]<CR><LF>

 - AT::command message prefix
 - CMD:command character string
 - [op] : command operate character, can be parameter setting or query
 - ◆ "-" : means parameter setting
 - ◆ "?" :means query
 - [para-n] : parameter setting code, if query, it is not required.
 - <CR>:end ,ASCII code 0x0d;
 - <LF>: return,ASCII code 0x0a

<description>:

When input command,"AT:<CMD>" character is capital word, parameter parts is the same.

- Feedback message
 - AT:<RSP>[op] [para-1,para-2,para-3,para-4...]<CR><LF><CR><LF>**
 - AT:: feedback message prefix;
 - RSP: feedback character string, include:
 - ◆ “OK” : success
 - ◆ “ERP”:failed
 - ◆ “DENY”: operation denied
 - ◆ <CMD>: original command
 - [op] :-
 - [para-n] : the feedback parameter when query or error code when error happened
 - <CR>:ASCII code 0x0d
 - <LF>:ASCII code 0x0a
- Error code

Table7. Error Code list

Error code	Description
ERP	Invalid command
WRONG	Invalid parameter
DENY	Operation denied

4.2.2. Command List

Table8. AT Command List

Command Type	Data transmit direction	Save or not	Function description
"AT:HELP"	MCU->Module	No	Helo command
" AT:REN-" + Name	MCU->Module	Yes	Set module NAME
" AT:REN? "	MCU->Module	Query	Query module NAME
"AT+CIT-" +IntervalMin+IntervalMax +Slave Latency+connSupervision Timeout	MCU->Module	Yes	Set connect parameter
"AT+CIT? "	MCU->Module	Query	Query connect parameter
"AT:BPS-" + baudrate	MCU->Module	Yes	Set baud rate
"AT:BPS? "	MCU->Module	Query	Query baud rate
"AT:MAC? "	(APP)MCU->Module	Query	Query MAC
"AT:VER? "	(APP)MCU->Module	Query	Query software version

"AT:TPL-" +Data0+Data1	MCU->Module	Yes	Set transmit power
"AT:TPL? "	MCU->Module	Query	Query transmit power
"AT:ADP-" +parameters	MCU->Module	Yes	Set broadcast parameter
"AT:ADP? "	MCU->Module	Query	Query broadcast parameter
"AT:ADV-" + Data	MCU->Module	Yes	Set user-define broadcast data
"AT:ADV? "	MCU->Module	Query	Query user-define broadcast data
"AT:ADVAL"+data	MCU->Module	Yes	Set auto-broadcast switch
"AT:ADVAL? "	MCU->Module	Query	Query auto-broadcast switch
"AT:ADVSTART"	MCU->Module	No	Start broadcast
"AT:ADVSTOP"	MCU->Module	No	Stop broadcast
"AT:CNN-D"	MCU->Module	No	Disconnect
"AT:PID-" + Data	(APP)MCU->Module	Yes	Ser device verify code
"AT:PID? "	(APP)MCU->Module	Query	Query device verify code
"AT:SAVE"	(APP) MCU->Module	No	Save parameter
"AT:RST"	MCU->Module	No	Restore module
"AT:RELD"	MCU->Module	no	Restore factory setting via AT command
PIN32->WAKEUP high level outside	MCU->module	Notification	Enable module CPU subsystem deep sleep (BLE subsystem isolated operation)
PIN29->MANUFACTURE	MCU->Module	-	Restore factory parameter via hardware

*Note:UART serial interface command must end with <CR><LF>,feedback must end with<CR><LF>

*Note: (APP) means the command is also applicable to APP command,APP command no need <CR><LF>

4.3. AT Command

4.3.1. AT:HELP Help command

Function: display all command description

Effective time: effective immediately

Command:

"AT:HELP"+<CR><LF>

feedback:

"AT:OK" +<CR><LF>+data mean command success, feedback description data

Data: list all command description data

"AT:ERP\r\n" means invalid command, query failed

4.3.2. AT:REN- Set Module NAME

Function: set module name, max length is 11 character

Effective time: effective after re-broadcast

Command:

" AT:REN-" + Name+<CR><LF>

Name : display the name, max 11 character

Feedback:

"AT:OK\r\n" means success

"AT:WRONG\r\n" means invalid parameter, set failed

"AT:ERP\r\n" means invalid command, set failed

4.3.3. AT:REN? Query module Name

Function: query module current Name

Command

"AT:REN? "+<CR><LF>

'?': means query

Feedback

"AT:REN-" + devicename +<CR><LF> means success

Devicename: device name can be displayed, max 11 character, default factory name is "HF-BL300"

"AT:ERP\r\n0" means invalid command, failed

4.3.4. AT:CIT- Set Connect Parameter

Function: set BLE connect parameter

Effective time: effect immediately at connection status or effective after connection

Command:

"AT:CIT- "+IntervalMin+IntervalMax+Slave Latency+connSupervision Timeout+<CR><LF>

IntervalMin: 4 character means, HighByte |...| LowByte; '0'~'9' means 0~9, "0200"-> decimal 200*1.25ms

IntervalMax: 4 byte means ,HighByte |...| LowByte; '0'~'9' means 0~9, "1000"-> decimal 1000*1.25ms

Slave Latency: 1 character, '0'~'9' means 0~9,

connSupervision Timeout: 4 character means ,HighCharacter |...| LowCharacter, '0'~'9' means 0~9, "2000"-> decimal 2000*10ms

when connect to IOS APP ,Apple has their own regulation, for parameter must comply :

1. IntervalMax* (Slave Latency+1) 《=2 seconds
2. IntervalMin>=20ms
3. IntervalMin +20ms<=IntervalMax
4. Slave Latency<=4
5. connSupervision Timeout<=6 seconds
6. IntervalMax*(Slave Latency+1)*3<connSupervisionTimeout

Feedback:

"AT:WRONG\r\n" means invalid parameter, modify failed

"AT:OK\r\n" means success, run with new connect interval

"AT:ERP\r\n" means invalid command, modify failed

4.3.5. AT:CIT? Query Connect Parameter

Function: Query module connect parameter

Effective time: immediately

Command:

"AT:CIT?"<CR><LF>

Feedback:

"AT+CIT="+IntervalMin+IntervalMax+Slave Latency+connSupervision Timeout+<CR><LF>

IntervalMin:4 character means ,HighByte |...| LowByte;'0'~'9' means 0~9,"0200"-> decimal 200*1.25ms

IntervalMax:4 character means,HighByte |...| LowByte;'0'~'9' means 0~9,"1000"-> decimal1000*1.25ms

Slave Latency:1 character,'0'~'9' means 0~9,

connSupervision Timeout:4 character means ,HighByte|...|LowByte,'0'~'9' means 0~9,"2000"-> decimal 2000*10ms

when connect to IOS APP ,Apple has their own regulation, four parameter must comply:

7. IntervalMax* (Slave Latency+1) ≤2 seconds
8. IntervalMin≥20ms
9. IntervalMin +20ms≤IntervalMax
10. Slave Latency≤4
11. connSupervision Timeout≤6 seconds
12. IntervalMax*(Slave Latency+1)*3<connSupervisionTimeout

"AT:ERP\r\n" means invalid command, query failed

4.3.6. AT:BPS- Set Baud rate

Function: modify UART Baud rate

Effective time:effective after receiving the success feedback data

Command:

"AT:BPS="+baud rate+<CR><LF>

Baudrate:6 character,'0'~'9' means 0~9,"115200"-> decimal 115200

Feedback:

"AT:OK\r\n" means success

"AT:WRONG\r\n" means invalid parameter, modify failed

"AT:ERP\r\n" means invalid command, modify failed.

Remark: only apply regular baud rate 4800,9600,19200,38400,57600,115200,230400,921600 other parameter would be consider invalid.

4.3.7. AT:BPS? Query Baud rate

Function: query current baud rate

Effective time:immediately

Command:

"AT:BPS? "+<CR><LF>

Feedback:

"AT:BPS-"+baud rate+<CR><LF> means success

Baudrate:6 character , '0'~'9' means 0~9,"115200"-> decimal 115200,"038400"-> decimal 38400

"AT:ERP\n" means invalid command, query failed

4.3.8. AT:MAC? Get MAC Address

Function: Get Bluetooth MAC

Command:

"AT:MAC?"+<CR><LF>

APP Command do not need <CR><LF>

Feedback:

" AT:MAC-"+MAC+<CR><LF>

MAC: 12 character can represent 6 byte data, each 2 character represent the four bit in high order and the four bit in low order of one byte.

e.g. :“123456789012”->0x12,0x34,0x56,0x78,0x90,0x12, character can only be '0'~'9','A'~'F'

APP Command do not need <CR><LF>

4.3.9. AT:VER? Query Software Version

function:Query device current software version

Effective time:immediately

Command:

"AT:VER? "+<CR><LF>

APP Command do not need <CR><LF>

Feedback:

"AT:VER-"+version+<CR><LF> means query success

APP Command do not need <CR><LF>

Version: character string, e.g. "100-CU-V*.*"

"AT:ERP\r\n" means invalid command, query failed

APP Command do not need "\r\n"

4.3.10. AT:TPL- Set Transmit Power

Function: modify device transmit power, broadcast power and connect power

Effective time:immediately

Command

"AT:TPL"+Data0+Data1+<CR><LF>

Data0: broadcast power, one character, '1'~'8' means 1~8,

Data1: connect power, one character, '1'~'8' means 1~8,

- 1-> -30dbm
- 2-> -24dbm
- 3-> -15dbm
- 4-> -8dbm
- 5-> -3dbm
- 6-> 0dbm
- 7-> +2dbm
- 8-> +3dbm

Feedback:

"AT:OK\r\n" means command successfully received

"AT:WRONG\r\n" means invalid parameter, modify failed, if not '1'~'8', then it is invalid parameter

"AT:ERP\r\n" means invalid command, modify failed

4.3.11. AT:TPL? Query Transmit Power

Function: query device current transmit power , broadcast power, connect power

Effective time:immediately

Command:

"AT:TPL? "+<CR><LF>

'?': means query command

Feedback:

"AT:TPL-"+Data0+Data1+<CR><LF>

Data0: broadcast power ,one character, '1'~'8' means 1~8,

Data1: connect power, one character, '1'~'8' means 1~8,

1-> -30dbm

2-> -24dbm

3-> -15dbm

4-> -8dbm

5-> -3dbm

6-> 0dbm

7-> +2dbm

8-> +3dbm

"AT:ERP\r\n" means invalid command, query failed

4.3.12. AT:ADP- Set Broadcast Parameter

Function: set broadcast parameter, min. interval/max interval/broadcast type/broadcast channel

Effective time:effect in next broadcast

Command:

"AT:ADP-"+parameters+<CR><LF>

Parameters: includes 13 character, min interval ->4 character, max interval ->4 character,broadcast type->1 character, broadcast channel ->1 character

Min interval:HighByte|...|LowByte,'0'~'9' means 0~9("100"-> decimal 100), unit :0.625ms

Max interval:HighByte|...|LowByte,'0'~'9' means 0~9("1200"-> decimal 1200) ,unit:0.625ms

Broadcast type:'0'~'1' means 0~1,0->public,1->random,only public type available temporarily

Broadcast channel : '1'~'7' means 1~7,the three bit in low order correspond each channel index. bit0->channel37,bit1->channel->38,bit2->channel39 , the setting can be combined

Feedback:

"AT:OK\r\n" means command successful received

"AT:WRONG\r\n" means invalid parameter, change failed

"AT:ERP\r\n" means invalid command, change failed

4.3.13. AT:ADP? Query Broadcast Parameter

Function: query broadcast parameter, min interval/ max interval/ broadcast type/broadcast channel

Effective time:immediately

Command:

"AT:ADP?"<CR><LF>

Feedback:

"AT:ADP-"<parameters><CR><LF>

Parameters: include 13 character, min interval ->4 character, max interval->4 character, broadcast type->1 character, broadcast channel ->1 character

Min interval:HighByte|...|LowByte,'0'~'9' means 0~9("100"-> decimal 100) , unit:0.625ms

Max interval:HighByte|...|LowByte,'0'~'9' means 0~9("1200"-> decimal 1200) , unit:0.625ms

Broadcast:'0'~'1' means 0~1,0->public,1->random

Broadcast channel:'1'~'7' means 1~7,the three bit in low order correspond each channel index , bit0->channel37,bit1->channel->38,bit2->channel39, the setting can be combined.

"AT:ERP\r\n" means invalid command, query failed

4.3.14. AT:ADV- Set User-define Broadcast Data

Function: set the user-define data in broadcast, the max data length is 14 bytes

Effective time:effective in next broadcast

Command:

"AT:ADV-"<Data><CR><LF>

Data: max length is 11 bytes, data format must follow Bluetooth regulation

Feedback:

"AT:OK\r\n" means command successful received

"AT:WRONG\r\n" means invalid parameter, change failed

"AT:ERP\r\n" means invalid command, change failed

4.3.15. AT:ADV? Query User-define Broadcast Data

Function: query the data in user-define broadcast, max data length is 14 bytes

Effective time:immediately

Command:

"AT:ADV? "+<CR><LF>

Feedback:

"AT:ADV-"+data+<CR><LF> means command successful received and feedback data

Data: max length is 11 bytes, data format must follow Bluetooth regulation

"AT:ERP\r\n" means invalid command, change failed

4.3.16. AT:ADVAL- Set Auto-broadcast Switch

Function: auto start broadcast when module power on and disconnection

Effective time:effective when disconnect

Command:

"AT:ADVAL-"+data+<CR><LF>

Data:'0'->disable,'1'-> means enable

Feedback:

"AT:OK\r

\n" means command successfully received

"AT:WRONG\r\n" means invalid parameter, command failed

"AT:ERP\r\n" means invalid command, command failed

4.3.17. AT:ADVAL? Query Auto-broadcast Switch

Function: query the functions status of auto-broadcast

Effective time:immediately

Command:

"AT:ADVAL? "+<CR><LF>

Feedback:

"AT:ADVAL-"+status+<CR><LF> feedback current auto-broadcast switch function parameter

Status: each character indicate a status

'0'-> disable

'1'-> enable

"AT:WRONG\r\n" means invalid parameter, query failed

"AT:ERP\r\n" means invalid command, query failed

4.3.18. AT:ADVSTART Start Broadcast

Function: device start broadcast

Effective time: do not execute if under broadcast status and connect status, execute immediately under other status

Command:

"AT:ADVSTART"+ <CR><LF>

Feedback:

"AT:OK\r\n" means command successfully received and start broadcast

"AT:ADVSTART-"+status+<CR><LF> means command successfully received, but status incorrect

Status: each character indicate a status

'0'-> CYBLE_CNN_INITIALIZING

'1'-> CYBLE_CNN_ADVERTISING

'2'-> CYBLE_CNN_CONNECTED

'3'-> CYBLE_CNN_DISCONNECTED

'4'-> CYBLE_CNN_STOPPED

'5'-> CYBLE_CNN_CONNECTING

"AT:ERP\r\n" means invalid command, command failed

4.3.19. AT:ADVSTOP Stop Broadcast

Function: stop broadcast

Effective time: execute immediately at broadcast status; do not execute if at other status

Command:

"AT:ADVSTOP"+ <CR><LF>

Feedback:

"AT:OK\r\n" means command successfully received and stop broadcast

"AT:ADVSTOP-"+status+<CR><LF> means command successfully received, but status incorrect

Status: each character indicate a status

'0'-> CYBLE_CNN_INITIALIZING

'1'-> CYBLE_CNN_ADVERTISING

'2'-> CYBLE_CNN_CONNECTED

'3'-> CYBLE_CNN_DISCONNECTED

'4'-> CYBLE_CNN_STOPPED

'5'-> CYBLE_CNN_CONNECTING

"AT:ERP\r\n" means invalid command, command failed

4.3.20. AT:CNN-D Disconnect

Function: device disconnect

Effective time:effective immediately if device at connect status; if at other status, do not execute command

Command:

"AT:CNN-D"+<CR><LF>

Feedback:

"AT:OK\r\n" means command received and executed

"AT:CNN-"+status+<CR><LF> means command received, but not executed because status incorrect

Status: each character indicate a status

'0'-> CYBLE_CNN_INITIALIZING

'1'-> CYBLE_CNN_ADVERTISING

'2'-> CYBLE_CNN_CONNECTED

'3'-> CYBLE_CNN_DISCONNECTED

'4'-> CYBLE_CNN_STOPPED

'5'-> CYBLE_CNN_CONNECTING

"AT:ERP\r\n" means invalid command, change failed

4.3.21. AT:PID- Set Device Verify Code

Function: change device verify code, all "0" means no verify code

Effective time:effective in next Bluetooth connection

Command:

"AT:PID-" + Data + <CR><LF>

APP command no need <CR><LF>

Data: 4 character means 1 hexadecimal data, '0'~'9', 'A'~'F' means 0~9, A~F ("12AD"-> hexadecimal 0x12AD)

Feedback:

"AT:OK\r\n" means command successfully received.

"AT:WRONG\r\n" means invalid parameter, change failed

"AT:ERP\r\n" means invalid command, change failed

APP command no need "\r\n"

4.3.22. AT:PID? Query Device Verify Code

Function: query device verify code parameter, all '0' means no verify code

Effective time: immediately

Command:

"AT:PID? " + <CR><LF>

'?': means query command

APP command no need <CR><LF>

Feedback:

"AT:PID-" + Data + <CR><LF>

APP Command no need <CR><LF>

Data: 4 Character means 1 hexadecimal data, '0'~'9', 'A'~'F' means 0~9, A~F ("12AD"-> hexadecimal 0x12AD)

"AT:ERP\r\n" means invalid command, query failed

APP Command no need "\r\n"

4.3.23. AT:SAVE Save Parameter

Function: save the changed parameter (the save will stop BLE function and other interrupt, after save, system will restore)

Effective time: immediately, save will stop BLE function and other interrupt, after save, system will restore

Command:

"AT:SAVE"+<CR><LF>

APP command no need <CR><LF>

Feedback:

"AT:OK\r\n" means command correct

"AT:ERP\r\n" means invalid command, command failed

APP Command no need "\r\n"

4.3.24. AT:RST Module Restore

Function: module restore, system software restore

Effective time: stop BLE function ,execute immediately

Command:

"AT:RST"+<CR><LF>

Feedback:

"AT:OK\r\n" means command successfully received

"AT:ERP\r\n" means invalid command, change failed

4.3.25. AT:RELD Restore Factory Setting via At Command

function:all changeable parameter restore to factory setting, include baud rate, device name, transmit power, user-define broadcast data, UART data latency data, verify code ,broadcast parameter, connect parameter

Effective time:immediately,system compulsory restore

Command:

"AT:RELD"+<CR><LF>

Feedback:

"AT:OK\r\n" means command success, system restore

"AT:ERP\r\n" means invalid command, restore failed

4.3.26. AT:UIDS Change Service UUID

Function: Set service UUID

Effective time: Need reboot

Command:

"AT:UIDS"+<CR><LF>

Feedback:

"AT:OK\r\n" means command successfully received

"AT:ERP\r\n" means invalid command, change failed

For APP to change this, does not need "\r\n"

4.3.27. AT:UIDR Change APP Receive Channel UUID

Function: Set Receive Channel UUID

Effective time: Need reboot

Command:

"AT:UIDR"+<CR><LF>

Feedback:

"AT:OK\r\n" means command successfully received

"AT:ERP\r\n" means invalid command, change failed

For APP to change this, does not need "\r\n"

4.3.28. AT:UIDW Change APP Send Channel UUID

Function: Set Send Channel UUID

Effective time: Need reboot

Command:

"AT:UIDW"+<CR><LF>

Feedback:

"AT:OK\r\n" means command successfully received

"AT:ERP\r\n" means invalid command, change failed

For APP to change this, does not need "\r\n"

5. APP COMMAND

5.1. Channel and Data Description

- APP command don't send in groups
- Maxium data of one group command is 20 bytes
- Data Channel:0x2B13 send WriteWithResponse and receive notify

5.2. Data Format

- Byte length (1 byte) + command type (1 byte) + command content (max 18 bytes)
- APP-->MODULE

Table9. Command Data from APP to Module

Byte length	Data[0]	1 byte	Include all byte of command type and command content
Command type	Data[1]	1 byte	0x0E: almost 18 bytes in one group AT command 0x0F: send verify code
Command content	Data[2]~data[19]	18 bytes	Details refer to command list (command type)

- APP<--MODULE

Table10. Feedback Data from Module to APP

Byte length	Data[0]	1 byte	Including all bytes from command type and command content
Feedback type	Data[1]	1 byte	0x0E:maxium 18 bytes in one group AT command 0x0F: feedback verify result
Command content	Data[2]~data[19]	18 bytes	Details refer to feedback list (feedback type)

5.3. Command Content

5.3.1. Command Type:0x0E

Command:

Function: data write in the form of 0x2B13 write with response , verify code command refer to AT command 4.3.23 &4.3.24, query version command refer to AT command 4.3.10

Feedback:

Channel:feedback data from 0x2B13 notify

Data content:

verify code command refer to AT command 4.3.23 &4.3.24, query version command refer to AT command 4.3.10

5.3.2. Command Type:0x0F

Command:

Function: send verify code from APP to module, if no verification after connection, module will not execute any other command from APP, if module self verification is null or “0000”, then verify code is no needed.

Verify code have time limit, if no verification within 10 seconds, module will disconnect with APP

Command Content:

Table11. Command Type 0x0F command list

Byte length	Data[0]	1 byte	1~19	Include all bytes from command type and command content
Command type	Data[1]	1 byte	0x0F	Verify code command
Command	Data[2]~data[19]	18 bytes	Data[2]~data[19]	Command content

Feedback:

Channel:feedback data from 0x2B13 notify

Data Content:

Table12. Command Type 0x0F Feedback List

Byte length	Data[0]	1 byte	2	Include all bytes from command type and command content
command type	Data[1]	1 byte	0x0F	Verified and feedback

Command content	Data[2]	1 byte	Data[2]	Verification feedback 0x00: success 0x01: failed 0x02: no verify code
-----------------	---------	--------	---------	--

6. BASIC COMMUNICATION MECHANISIM

6.1. Application Service Data Channel (user-define application service UUID:0x2B00)

Table13. Description of User-define Service of All Channel

UUID	Channel attribute	function
0x2B10	Notify/WriteWithResponse	APP send enable command to module via this notify channel
		Under notify enable status, module send data to APP via notify channel
0x2B11	Read/WriteWithoutResponse	APP send data to module
0x2B12	WriteWithResponse	APP send OTA mode switch command
0x2B13	Notify/WriteWithResponse	APP command

6.1.1. Module->APP, UART Data Channel 【feature UUID:0x2B10】

Table14. 0x2B10 feature UART Module->APP Channel Description

UUID	Executable operation	Bytes	Default value	Remark
0x2B10	Notify/WriteWithResponse	20	Null	Module receive data from UART RX, and notify APP via notify channel

Remark: data input from UART and output to Bluetooth. If turn on notify enable switch, outside MCU will send data to module RX via UART, and create a notify event in the channel, APP can directly process in the callback function.

6.1.2. APP->Module, UART Data Channel 【feature UUID:0x2B11】

Table15. 0x2B11 Feature UART APP->Module Channel Description

Feature value UUID	Executable operation	Byte	Default value	remark
0x2B11	Read/WriteWithout Response	20	null	APP write data to module via "write" channel, module output data via UART

Description :input from Bluetooth and output via UART. APP write data via "Write" channel, the data will output via UART TX.

6.1.3. APP->Module,OTA Mode Switch 【Feature UUID:0x2B12】

Table16. 0x2B12 Feature OTA Mode Switch Channel Description

Feature value UUID	Executable operation	Byte	Default value	remark
0x2B12	WriteWithoutResponse	20	Null	Mode switch: switch from application mode to OTA status, command data is :“bootloader”

6.1.4. APP->Module,APP Command Channel 【Feature UUID:0x2B13】

Table17. 0x2B13 Feature APP Command Channel Description

Feature value UUID	Executable operation	Byte	Default value	remark
0x2B13	Notify/WriteWithResponse	20	null	APP command, details refer to AT command :4.3.9、 4.3.10、 4.3.23、 4.3.24 Note:APP do not need to add the "AT:" prefix for AT comamnd

6.2. Battery Service Data Channel

Battery service UUID: 0x180F

Table18. Description of Battery Service of All Channel

UUID	Channel attribute	function
0x2A19	read	Read electricity

6.2.1. APP->Module,Battery Data Channel 【Feature UUID:0x2A19】

Table19. 0x2A19 Feature Battery Power Channel Feature Description

Feature value UUID	Executable operation	byte	Default value	remark
0x2A19	Read	1	null	Unit is 20mV

6.3. OTA Service Data Channel

OTA service UUID:00060000-F8CE-11E4-ABF4-0002A5D5C51B

Table20. Description of OTA Service of All Channel

UUID	Channel attribute	function
00060001-F8CE-11E4-ABF4-0002A5D5C51B	WriteWithResponse	OTA data transmit

6.3.1. APP->Module,OTA Data Channel

Table21. Feature OTA Data Channel Feature Description

Feature value UUID	Executable operation	byte	Default value	remark
00060001-F8CE-11E4-ABF4-0002A5D5C51B	WriteWithResponse	20	null	OTA data under "bootloader" mode, OTA mode receive program data and cover FLASH relative area

7. PACKAGE INFORMATION

7.1. Reflow Soldering Profile

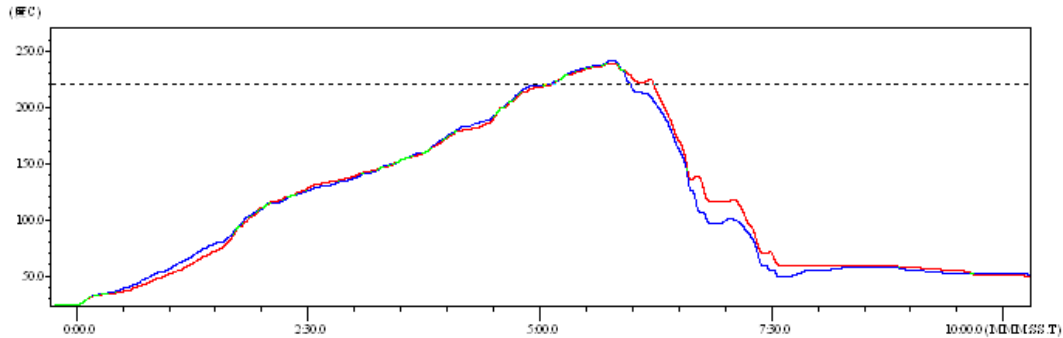

Figure 11. Reflow Soldering Profile

Table 22. Reflow Soldering Specification

Number	Item	Temp (°C)	Time(s)
1	Reflow time	220 °C above	35~55 s
2	Peak temp	Max 260 °C	

Remark: 1. Recommend to supply N2 for reflow oven
2. O2 content lower than 300ppm;

7.2. Handling Instruction

1. Shelf life in sealed bag: 12 months at <math> < 30^{\circ}\text{C}</math>, <math> < 60\%</math> humidity.
2. After bag opened, device need to be re-baked if window time over 168 hours
3. Recommended to over bake with N2 supplied
4. Recommended to reflow oven with N2 supplied
5. Bake required with 24 hours at $125 \pm 5^{\circ}\text{C}$,
6. Recommended to store at $\leq 10\%$ RH with vacuum packing
7. If SMT process needs twice reflow
 - (1) TOP side
 - (2) BOT side

Case 1: BLE module mounted on PCB TOP, need to bake TOP side after BOT side processed 168 hours (window time)

Case 2: BLE module mounted on PCB BOT side ,follow normal bake rule.

Remark: window time means it is been 168 hours since last bake to next flow.

APPENDIX A: UART TRANSPARENT TRANSMIT TYPICAL APPLICATION

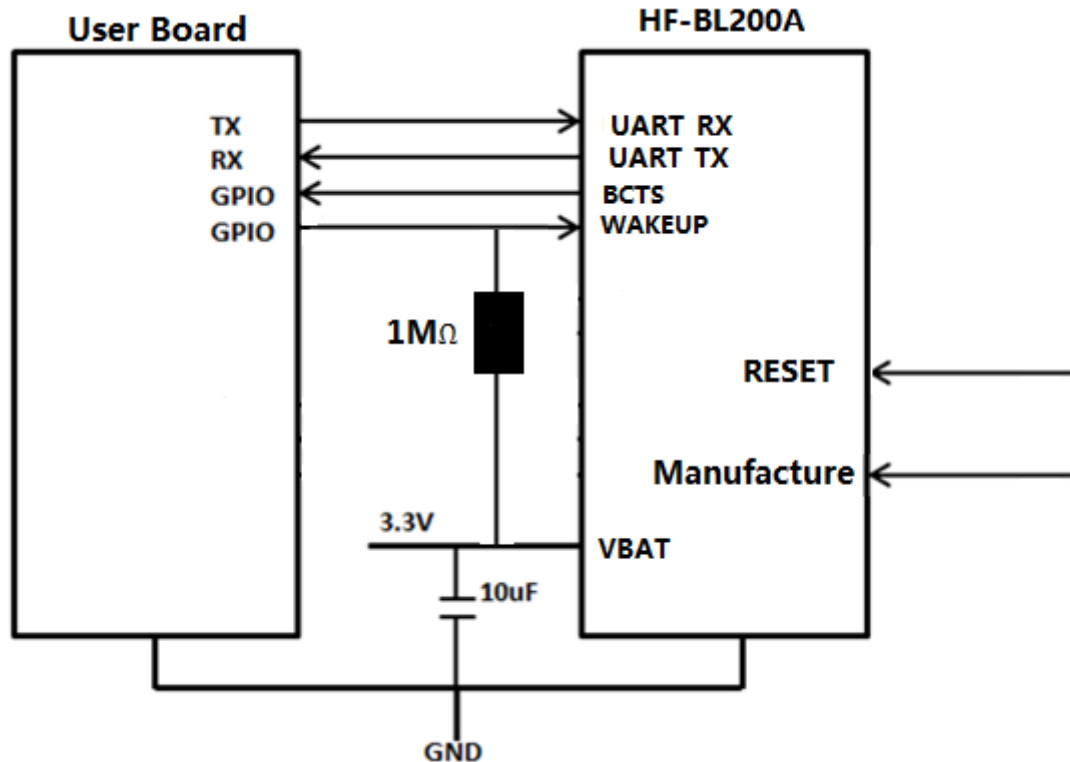

Figure 12. UART Transparent Transmit Typical Application

XRES-----module reset signal, input, low level valid

There is a pull-up resistor to VBAT, no need external pull up resistor. When module power on or failure, MCU will reset the module, pull down at least 10 ms then pull-up.

BCTS----- Module UART output notify signal, output (wakeup external MCU, remind MCU there is data output)

Module will pull down BCTS, and delay Xms before output data; X set by external MCU via At command, in default there is no latency. After sending data, BCTS pull-up, if there is new data sending BCTS will pull-up after sending all the new data. .

WAKEUP----- UART wakeup enable, Stop Mode Wakeup,(recommend to add external Pull-up resistor)

Pin Mode: WAKEUP pin is high resistor input. Can't be suspended, can be controller by pull-up or pull down or external MCU

UART Wakeup Enable: when WAKEUP is pull-up, all system enter into DEEPSLEEP ; when WAKEUP is pull-down, system enter into SLEEP mode. When sending data from external MCU to module, need to pull-down WAKEUP pin, after sending finished, pull-up WAKEUP to lower the power.

There must be a latency from WAKEUP pull-down to MCU sending data, the time is no less 拉低 than 2ms。

Stop Mode Wakeup:WAKEUP pull-down, AT command send out Stop command, when system enter into STOP mode, can be wakeup through pull-up WAKEUP.

UART_TX/RX-----UART data send/receive signal。

Manufacture (RELD) -----restore factory setting via hardware method: keep low level at least 5 second when power on or restore

APPENDIX D: CONTACT INFORMATION

Address: Room 1002 ,#1Building,No.3000 Longdong Avenue, Pudong District, Shanghai, China

Post Code:201203

Web: www.hi-flying.com

Online consult: 400-189-3108

Email: sales@hi-flying.com

For more information ,please visit <http://www.hi-flying.com/>

© Copyright High-Flying, May, 2011

The information disclosed herein is proprietary to High-Flying and is not to be used by or disclosed to unauthorized persons without the written consent of High-Flying. The recipient of this document shall respect the security status of the information.

The master of this document is stored on an electronic database and is "write-protected" and may be altered only by authorized persons at High-Flying. Viewing of the master document electronically on electronic database ensures access to the current issue. Any other copies must be regarded as uncontrolled copies.